

**INSTALLER: Leave this manual with the appliance.**  
**CONSUMER: Retain this manual for future reference.**

These instructions are supplementary to the Installation and Operating Instructions supplied with the fireplace and should be kept together. Refer to the Installation and Operating Instructions for proper gas supply, safety requirements and operating instructions

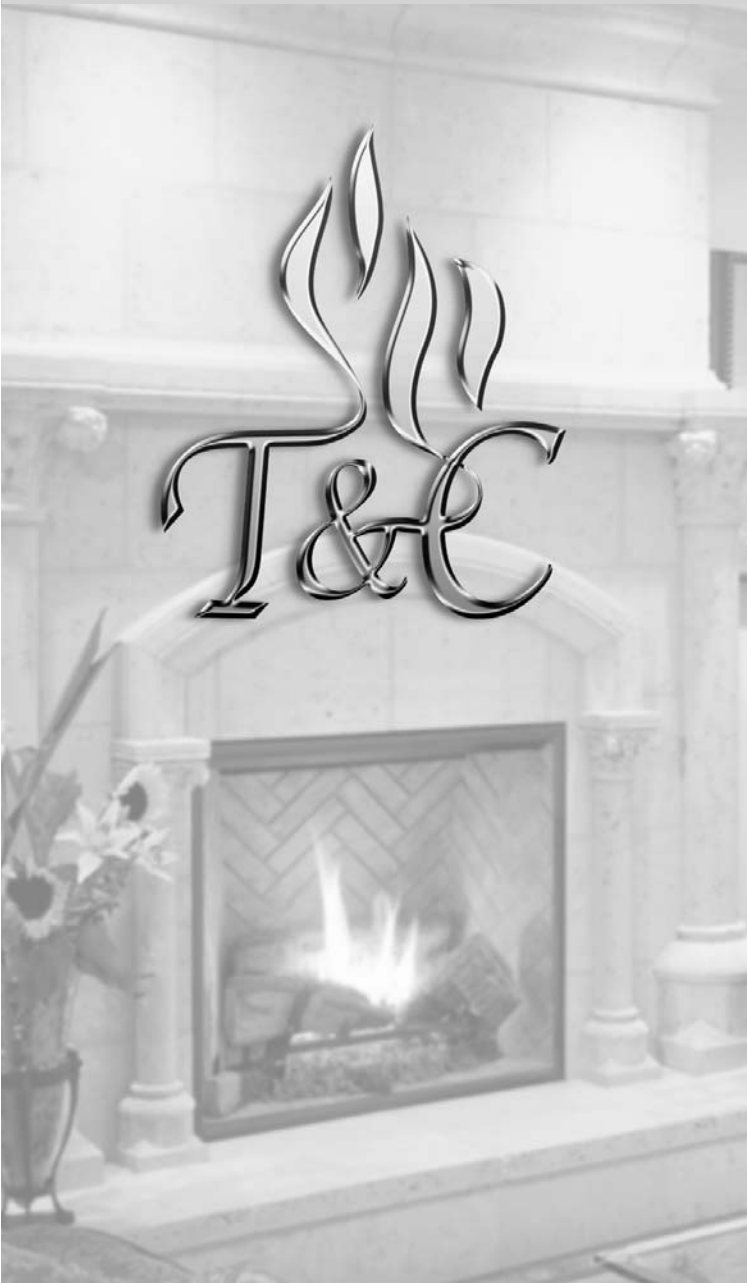

**TOWN & COUNTRY  
FIREPLACES™**

## **OPTIONAL VERTICAL OR HORIZONTAL POWER VENT KIT**

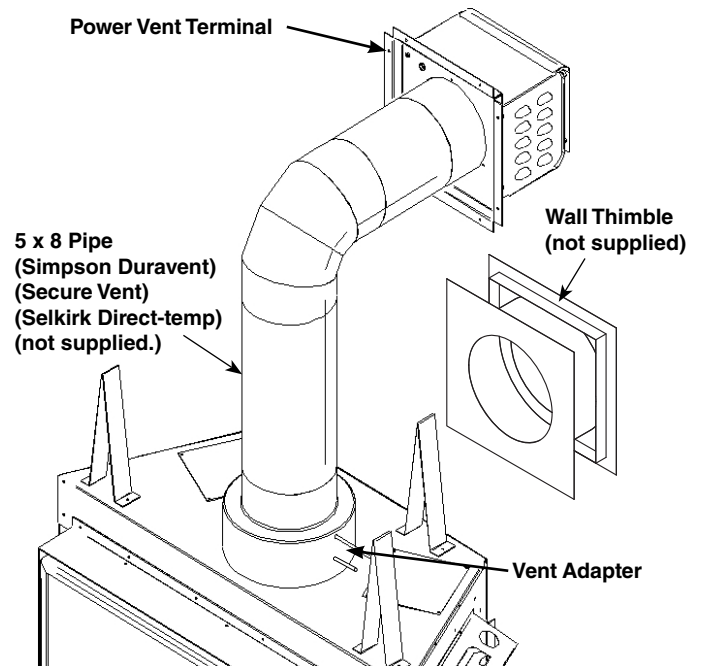

**TCVT.PVB2  
INSTALLATION AND  
OPERATING  
INSTRUCTIONS**



# Power Vent Installation

Locate the fireplace as per the main instructions supplied. Make the following modifications to add the components used with the Power Vent kits. This kit can only be used in conjunction with the "B" & "C" series versions of Town and Country Fireplaces. This installation must conform with local codes or, in the absence of local codes, with the Natural Fuel Gas Code, ANSI Z223.1/NFPA 54, or the Natural Gas and Propane Installation Code, CSA B149.1.

All electrical installation should be performed by a qualified electrician to national codes (CSA C22.1, ANSI/NFPA 70) and/or local electrical codes.

## Contents of Power Vent Kit

### MINIMUM CLEARANCES TO COMBUSTIBLE

Vertical vent pipe:  
1.5 in. (38mm)

Horizontal vent pipe:

Top 1.5 in. (38mm)  
Sides 1.5 in. (38mm)  
Bottom 1.5 in. (38mm)

All other clearances are as per the fireplace installation instructions.

ITEM	PART No.	DESCRIPTION	QTY
1	TCVT.502462	Power Vent Terminal	1
2	5096.814	Venting Adaptor	1
3	TCVT.506271C	Pressure Switch Wiring	1
4	5027.15	Pressure Switch	1
5	8024	Tubing, TYSC-516316-100	2
6	5093.01	Hose Clamp	2
7	5093.02	Hose Clamp	2
8	TCVT.507156C	Power Vent Switch Wire	1

Fig. #1

## Power Vent

### VENTING CONFIGURATIONS

Maximum vent length is 110 ft plus six 90-degree elbows or combination of other elbows equaling 90-degrees, with a maximum 66 foot vertical rise. Minimum vent length is 3 ft plus one 90-degree elbow. The vent can be installed with any combination of rise and run between the figures including up to 3 ft below the unit. Ensure vent pipe is properly supported.

Maximum Combined vertical & horizontal venting - 110 ft plus six 90-degree elbows.

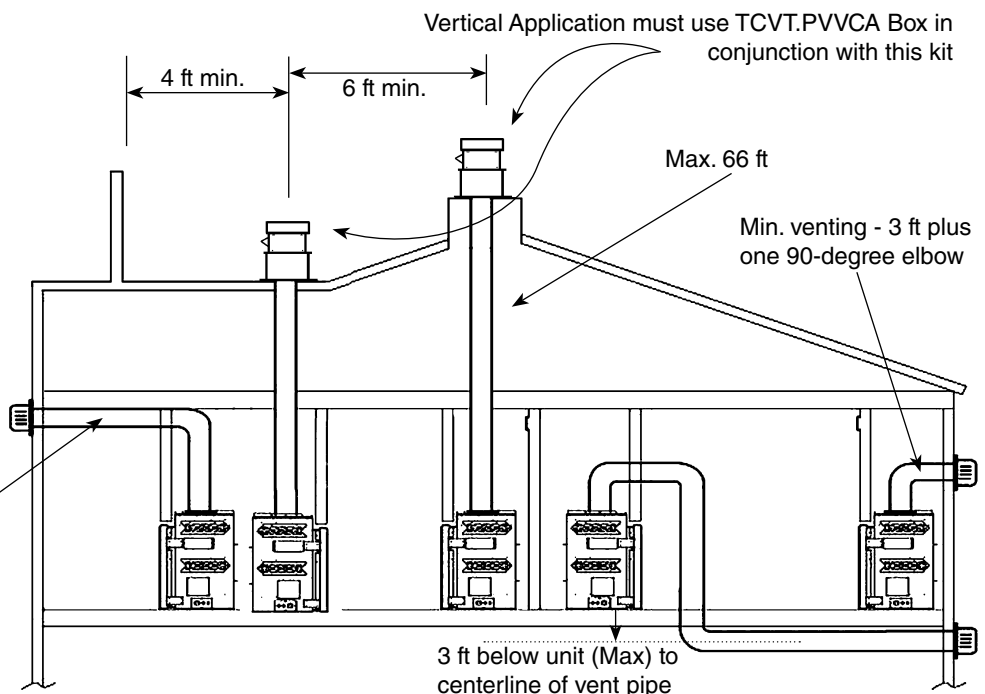

# Wall Termination Venting Chart

Fig. #1a

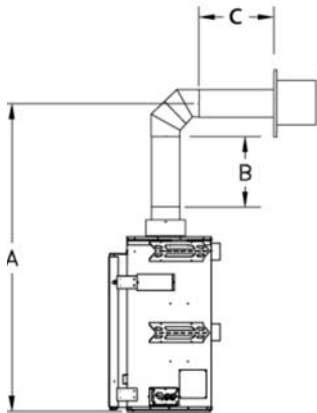

A						B	C	
Minimum Rise						Pipe Length	Max. Pipe Length	Min. Pipe Length
TCWS54	TCWS38	TC30	TC36	TC42	TC36ST			
49"	45"	47"	51"	57"	56"	0"	110 feet	3 feet
61"	47"	59"	63"	69"	68"	12"	109 feet	2 feet
73"	69"	71"	75"	81"	80"	24"	108 feet	1 foot

\*TC36 and TC36AR have the same dimensions

# Vent Terminal Minimum Clearances

Fig. #2

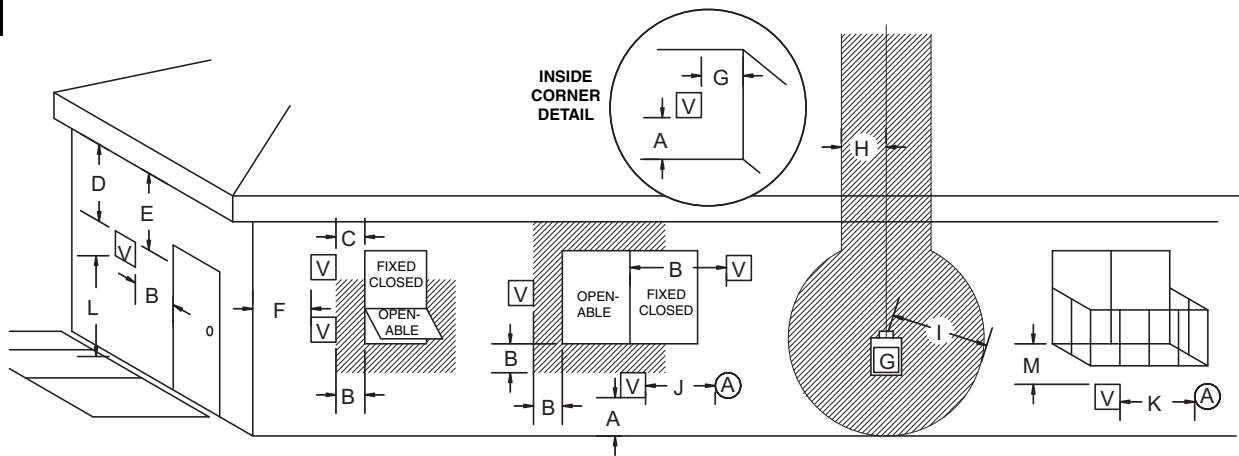

- V VENT TERMINAL
- A AIR SUPPLY INLET
- AREA WHERE TERMINAL IS NOT PERMITTED
- G GAS METER

- A= clearances above grade, veranda, porch, deck, or balcony [\* 12 inches (30 cm) minimum]
- B= clearance to window or door that may be opened [\* 12 inches (30 cm) minimum]
- C= clearance to permanently closed window [minimum 12 inches (30 cm) recommended to prevent condensation on window]
- D= vertical clearance to ventilated soffit located above the terminal within a horizontal distance of 2 feet (60 cm) from the edge of the terminal [12 inches (30 cm) minimum]
- E= clearance to unventilated soffit [12 inches (30 cm) minimum]
- F= clearance to outside corner [6 inches (15 cm) minimum]
- G= clearance to inside corner [6 inches (15 cm) minimum]
- H= \* not to be installed above a meter/regulator assembly within 3 feet (90 cm) horizontally from the center-line of the regulator
- I= clearance to service regulator vent outlet [\* 6 feet (1.8 m) minimum]
- J= clearance to nonmechanical air supply inlet to building or the combustion air inlet to any other appliance [\* 12 inches (30 cm) minimum]
- K= clearance to a mechanical air supply inlet [\* 6 feet (1.8 m) minimum]
- L= ^ clearance above paved side-walk or a paved driveway located on public property [\* 7 feet (2.1 m) minimum]
- M= clearance under veranda, porch, deck, or balcony [12 inches (30 cm) minimum\*\*]

^ a vent shall not terminate directly above a side-walk or paved driveway which is located between two single family dwellings and serves both dwellings\*

\*\* only permitted if veranda, porch, deck, or balcony is fully open on a minimum of 2 sides beneath the floor\*

\* as specified in CGA B149 Installation Codes, Note: local Codes or Regulation may require different clearances

\* for U.S.A. Installations follow the current National Fuel Gas Code, ANSI Z223.1

## VENT PIPE

This kit uses either Simpson Duravent GS direct vent pipe, Secure Vent direct vent pipe, Selkirk Direct-temp vent pipe or ICC Excel Direct vent pipe with a 5" inner pipe and an 8" outer pipe. For part numbers see the table of venting components on page 11 of this manual.

### CAUTION:

The adjustable vent restrictor located on the underside of the firebox top must be fully open.

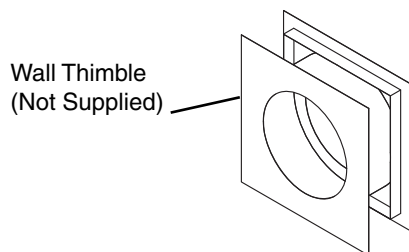
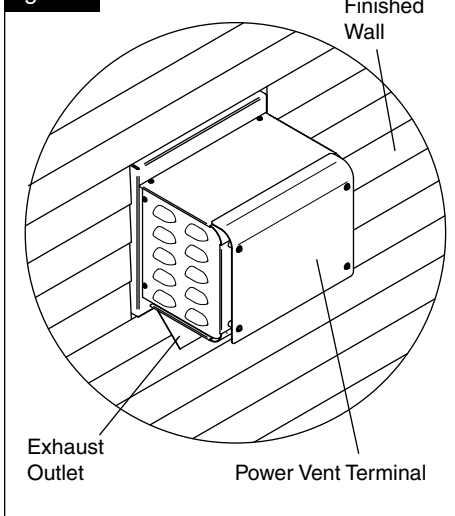

Fig. #3



## Horizontal (Side Wall) Venting

1. Locate the power vent termination following the clearance to combustible table, venting configuration diagram (Fig. #1 & 1a), and terminal location diagram (Fig. #2).
2. Cut and frame an 11" x 11" opening. The centre of the square hole should line up with the centre line of the horizontal pipe.
3. Install the Simpson Duravent (or equivalent) Wall thimble, part number 1247 (not supplied with kit) in the opening to retain any insulation in the wall and maintain proper clearances. If the wall being penetrated is constructed of noncombustible material only (i.e.. Masonry block or concrete) the wall thimble is not required and a hole with zero clearance is acceptable. (8" hole)
4. Drill an appropriate sized hole in the corner of the wall thimble that is in line with the wiring hole in the back of the power vent and bring the 14-2 electrical wire (not supplied) up through the holes in both the wall thimble and the back of the power vent.
5. Remove the Junction Box cover and join the 14-2 wire lead to the blower wires using the appropriate connectors and attach the ground wire. Reinstall the junction box cover.
6. Attach the terminal to the outside wall. Ensure that the terminal is the right way up and that only the outer flanges that are used to secure the terminal to the building are covered by the exterior wall or siding. (Fig.#3) **Note: No other part of the terminal can be recessed into the exterior wall or siding.**
7. Attach the vent adaptor directly to the appliance with three screws and seal outer pipe with aluminium tape provided. (Fig. #4)  
**Note: The inner pipe does not need to be sealed.**
8. Connect one of the high temperature silicone tubes to the upper pressure tap on the adaptor.(Fig. #4) Secure with the hose clamp provided and route the tube through any hole back to control box. This tube will be connected to the "low" side of the vacuum switch inside the control compartment. (Fig. #11) Connect the second tube to the lower pressure tap and route to the control box as before. Connect this tube to the remaining port on the vacuum switch. Tubes may touch unit and be trimmed if required. **Note: Ensure that there are no blockages in these tubes, as this will cause the control to malfunction.**
9. Run the required Simpson Duravent GS / Secure Vent / Selkirk Direct-temp/ ICC Excel Direct vent pipe from the adaptor to the terminal assembly. Assemble as per the vent pipe manufacturer's instructions including all shields and firestops.

Fig. #4

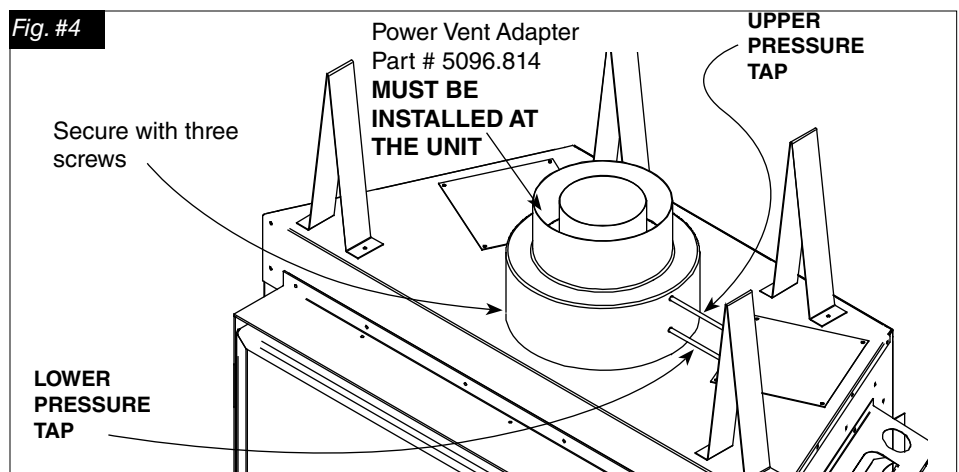

# Vertical (Through Roof) Venting

Vertical installations must use the optional TCVT.PVCA vertical adaptor box in conjunction with this kit. The vertical adaptor box can only be installed on a flat surface. Sloped surfaces require the construction of a chase which provides the minimum interior, square opening of 11" x 11" for the venting and wiring to pass through. Flat roofs may require a chase depending on local codes and roof construction. (If in doubt check with local inspector)

The terminal must be located in accordance with the clearances outlined in Fig. #1 and 2.

## Installation:

All part numbers in the following section are shown in Fig. #5.

1. Place the flashing (Part A) onto the chase and seal using silicone.
  2. Put a bead of silicone on the underside of the vertical standoff (Part B) and place it on top of the flashing. Align the eight holes and secure both parts to the chase using eight #8 x 1 1/2" screws provided.
  3. Install the drip shield (Part C) onto the top of the vertical standoff using a bead of silicone between the two. Do not screw this part in place.
  4. Bring the 14-2 electrical wire (not supplied) up through the holes in both the flashing and the drip shield leaving at least 12" of excess wire above the drip shield.
  5. IMPORTANT: Attach an appropriate length(s) of the vent to the power vent terminal, sufficient to pass through the chase.
- NOTE: DO NOT CONNECT AN ADJUSTABLE LENGTH VENT PIPE TO THE TERMINAL.**
6. Seal the connection of the first length of pipe at the terminal and any other pipe to pipe joint by both screwing and taping the outside joint using high temperature foil tape.
  7. Remove the junction box cover. (Part D)
  8. Remove and discard the exhaust shield. (Part E)
  9. Apply a bead of silicone on the bottom flange of the power vent terminal.
  10. Slide the vent through the drip shield and at the same time thread the electrical lead through the hole in the bottom of the

terminal.

11. With the power vent terminal resting on the drip shield, align the eight holes in each of the vertical standoff, the drip shield and the power vent terminal and then screw them together using the eight #8 x 1/2" stainless screws provided.
12. Join the 14-2 wire lead to the blower wires using the appropriate connectors and attach the ground wire. Reinstall the junction box cover.
13. Install the vertical rain cap (Part F) over the power vent blower. ALIGN THE EXHAUST OUTLET ON THE POWER VENT TERMINAL WITH THE EXHAUST PORT ON THE VERTICAL RAIN CAP.
14. Secure the vertical rain cap to the power vent blower with the remaining eight #8 x 1/2" stainless screws.

**NOTE:**  
THERE ARE NO PILOT HOLES IN THE BASE OF THE POWER VENT TERMINAL. 1/8" DIAMETER PILOT HOLES SHOULD BE DRILLED USING THE HOLES IN THE VERTICAL RAIN CAP AS A GUIDE.

DO NOT SILICONE THE VERTICAL RAIN CAP TO THE POWER VENT TERMINAL AS IT NEEDS TO BE REMOVABLE FOR SERVICING.

15. Attach the vent adaptor directly to the appliance with three screws. (Fig. #4)

**Note: The inner pipe does not need to be sealed.**

16. Connect one of the high temperature silicone tubes to the upper pressure tap on the adaptor. (Fig. #4) Secure with the hose clamp provided and route the tube through any hole back to control box. This tube will be connected to the "low" side of the vacuum switch inside the control compartment. (Fig. #11) Connect the second tube to the lower pressure tap

## VENT PIPE

This kit uses either Simpson DuraVent GS direct vent pipe, Secure Vent direct vent pipe, Selkirk Direct-temp vent pipe or ICC Excel Direct vent pipe with a 5" inner pipe and an 8" outer pipe. For part numbers see the table of venting components on page 11 of this manual.

**CAUTION:**  
The adjustable vent restrictor located on the underside of the firebox top must be fully open.

and route to the control box as before. Connect this tube to the remaining port on the vacuum switch. Tubes may touch unit and be trimmed if required. **Note: Ensure that there are no blockages in these tubes, as this will cause the control to malfunction.**

17. Run the required Simpson DuraVent GS / Secure Vent / Selkirk Direct-temp pipe from the adaptor to the terminal assembly. Assemble as per the vent pipe manufacturer's instructions including all shields and firestops.

# Vertical (Through Roof) Venting

**Fig. #5**

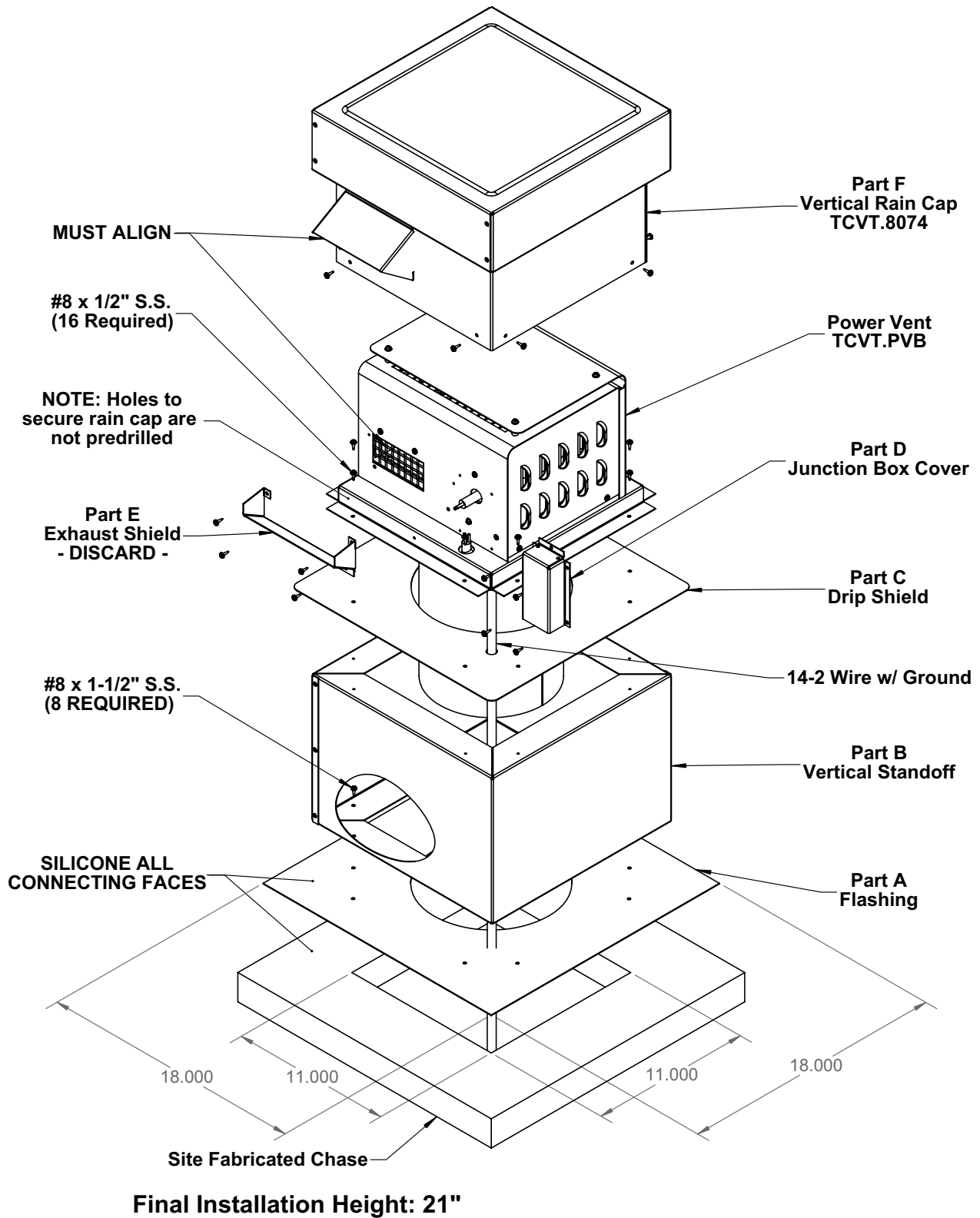

# Control System Connection

The gas control system is located on the right hand side of the firebox behind an access panel and the decorative panel.

1. Remove burner assembly, burner media and decorative panels if already installed (see main installation manual for details).
2. Remove access panel from right hand side of the firebox. (Fig. #6)
3. Locate and disconnect the spade connectors in the black wire loop on the right side of the module and in the orange wire running from the module to the socket labelled "pilot" on the valve. (Fig. # 6 and 7)
4. Using the jumper wires provided, connect the 120V "hot" supply wire to one of the black wires from the control module. Then connect the "hot" wire from the power vent blower to the other black wire on the control module. (Fig. #9) The module acts as a switch to turn on the power vent blower. (Also see wiring diagram on Pg.9)

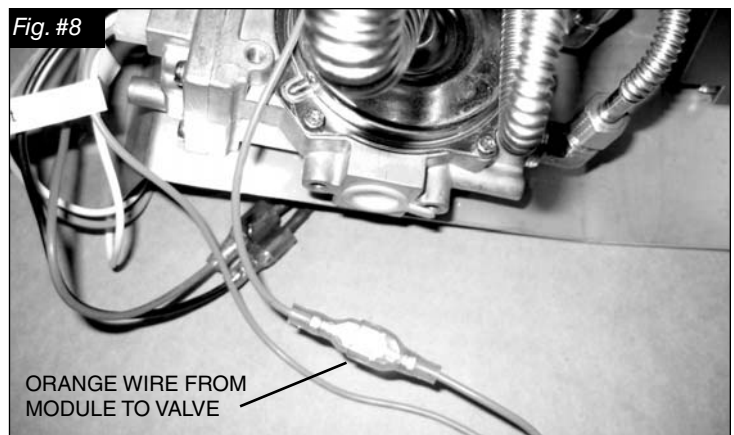
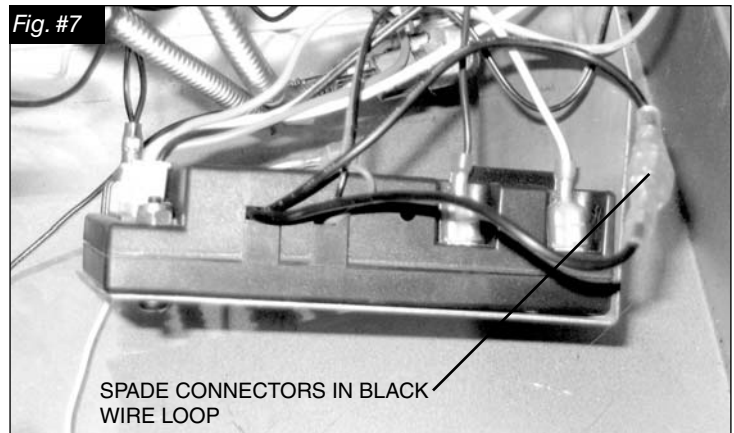
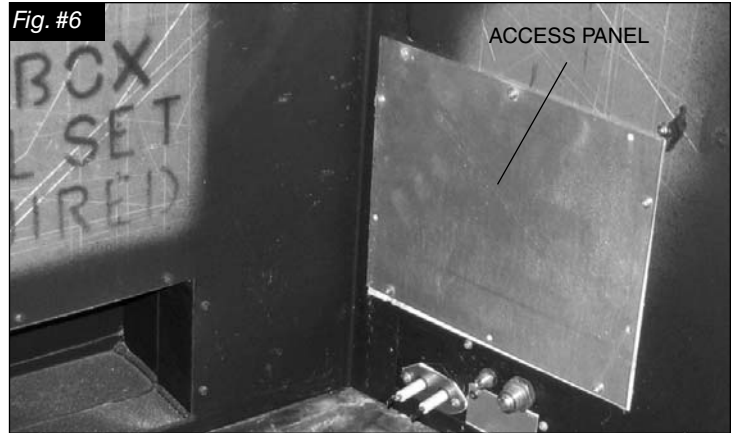

HOT WIRE FROM BLOWER

HOT WIRE FROM 120V SUPPLY

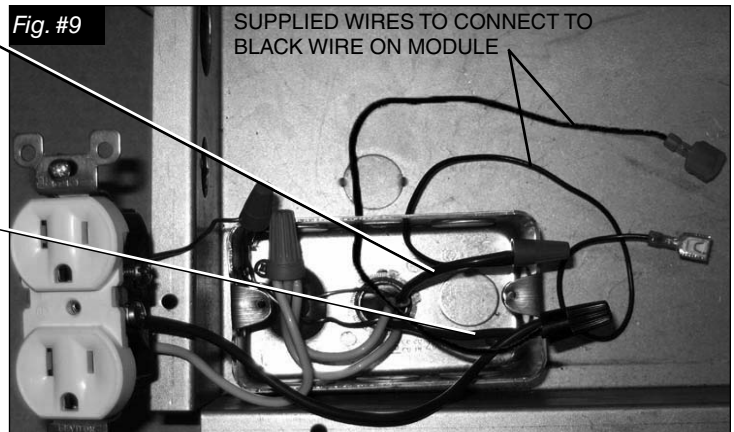

5. Connect the pressure switch jumper wires to the orange wire. (Fig. # 10)
6. Attach a silicone tube from the upper pressure tap on the power vent adaptor (Fig. #4) to the low port of the pressure switch. Attach the other silicone tube from the lower pressure tap to the high port of the pressure switch.
7. Secure the pressure switch in the control box using the screw provided. (Fig. #12)
8. Continue with installation and reassemble all of the parts previously removed.

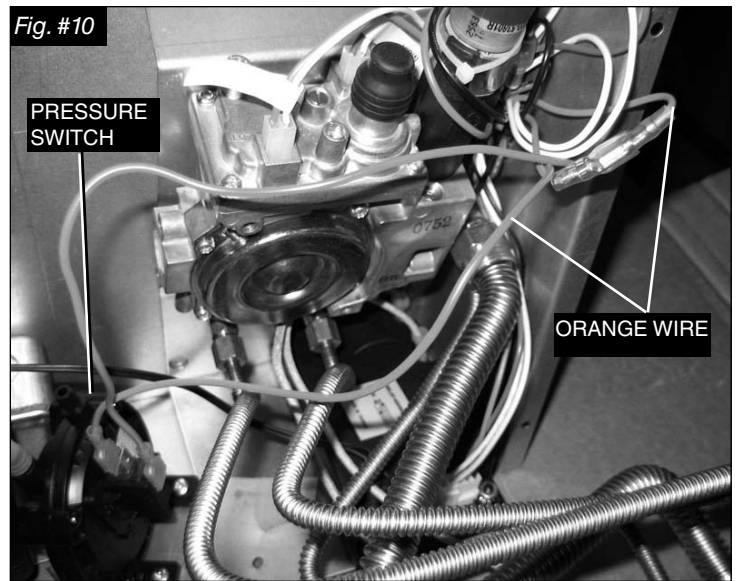

**WARNING: This switch must be installed in a vertical position and will not function if installed otherwise. (Fig. 13)**

**This power vent system can only run on 115 V AC. Before operating the unit, the battery backup located behind the wall switch receiver must be removed.**

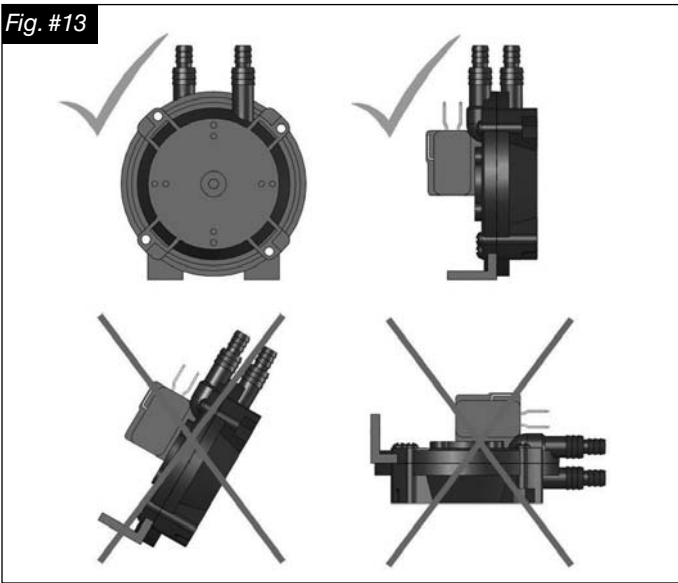
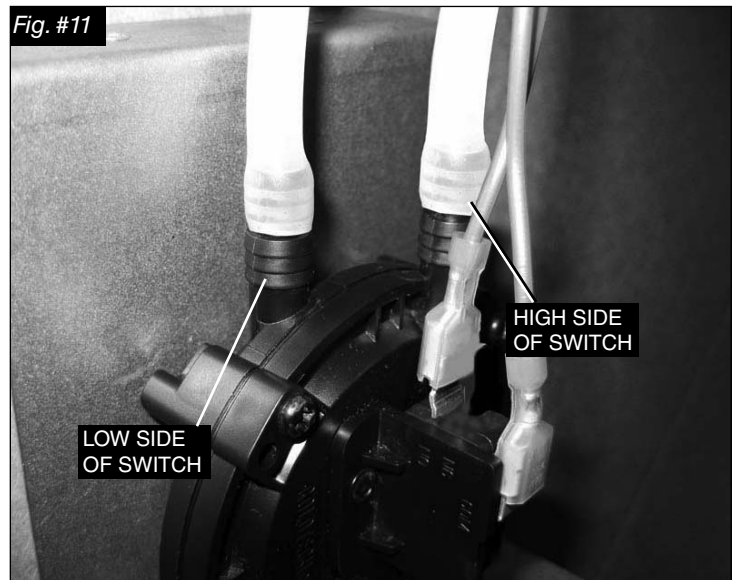

# Wiring Diagram

Wiring the Power Vent Kit provided by Town & Country

STANDARD AWG 14-2 WIRE  
OR EQUIVALENT (NOT SUPPLIED)

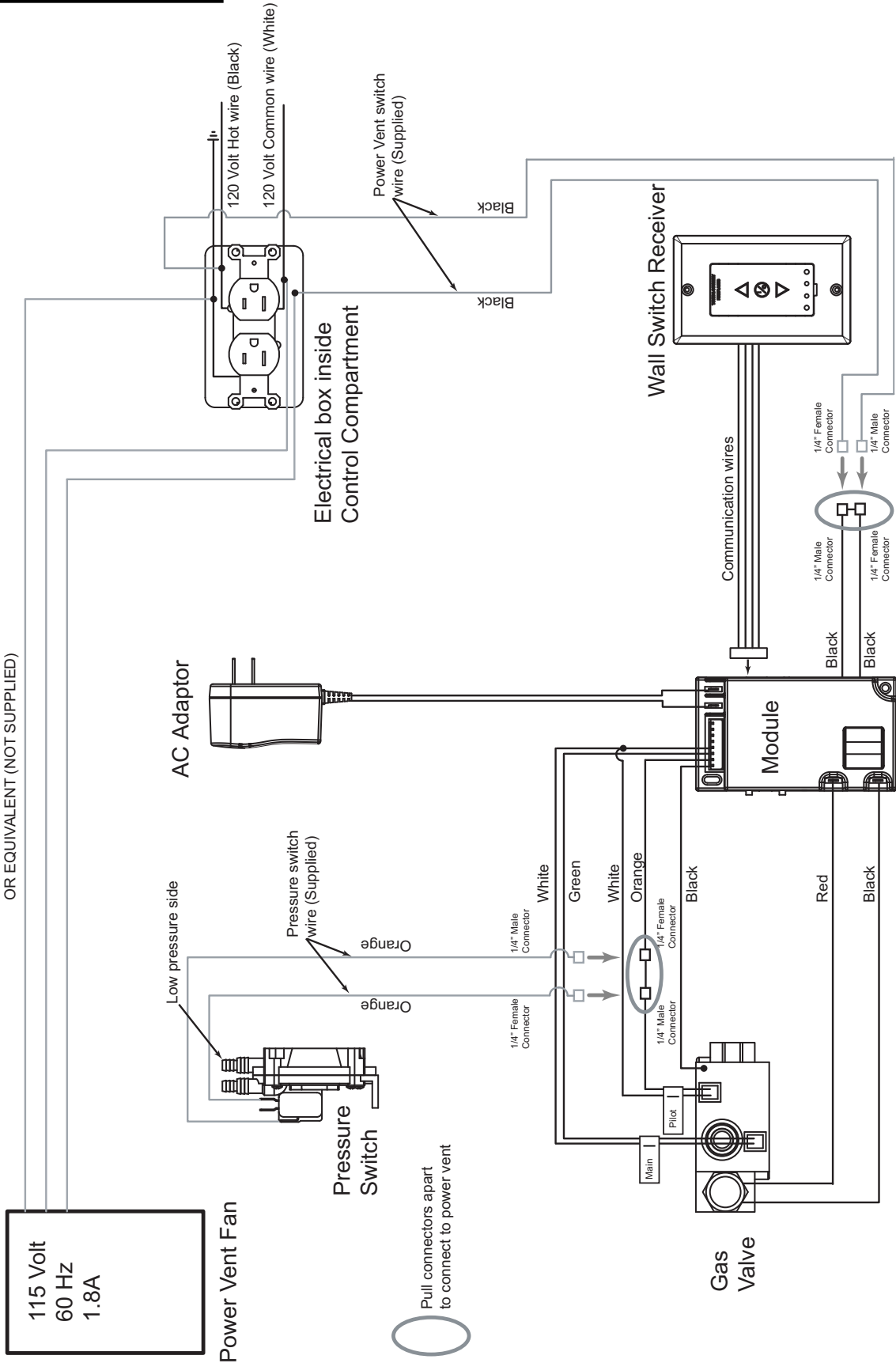

# Replacement Parts

ITEM	PART No.	DESCRIPTION	QTY
1	8024	TUBE, 5/16" OD, 1/16" THICK	2
2		BLOWER POWER VENT	1
3	5027.15	PRESSURE SWITCH	1
*4		3/8" STRAIN RELIEF	2
5		#8 x 1/2" PAN HD SKT 18.8 STAINLESS STEEL	46
6		ID x .379 OD x .062 THK	2
7		1/4 MED LOCKWASHER 18.8 SS	5
8		STANDARD 18-8 SS, #8 FLAT WASHER	6
9		SP100 .25 x .75 AK	4
10		SCREW, #8-32 x1 1/4 RND HD	4
*11		#8-32 x5/16 PAN QUADREX	1
12		HEX NUT, STAINLESS 18-8 PLAIN	4
13		1/4-20 x1/2 NC GR 5 HEX C/S PLTD	5
14	5096.814	VENTING ADAPTER	1
15		1/4" LDF PAPER	1
*17		BUSHING, SHORTY B625 500	2
18		SIDE COVER, RIGHT	1
19		SIDE COVER, LEFT	1

ITEM	PART No.	DESCRIPTION	QTY
20		INSIDE COVER	1
21		EXHAUST SHIELD	1
22		SECONDARY RAIN SHIELD	2
23		JUNCTION BOX	1
24		TOP COVER	1
25		EXHAUST SCREEN	1
26		FLASHING	1
27		OUTLET AIR CHANNEL	1
28		DRIP SHIELD	1
30		VENT COLLAR	1
31		VENT EXHAUST ASSEMBLY	1
32		VERTICAL RAIN CAP, TCVT	1
33		VERTICAL STANDOFF	1
34		BLOWER WIRING	1
35	TCVT.506271C2	PRESSURE SWITCH WIRING	1
36	TCVT.507156C	POWER VENT SWITCH WIRE	1

ITEM 35 AND 36 ARE USED WITH SERIES "C" FIREPLACES ONLY

\* NOT SHOWN

ONLY ITEMS WITH PART NUMBERS SHOWN ARE SOLD SEPARATELY

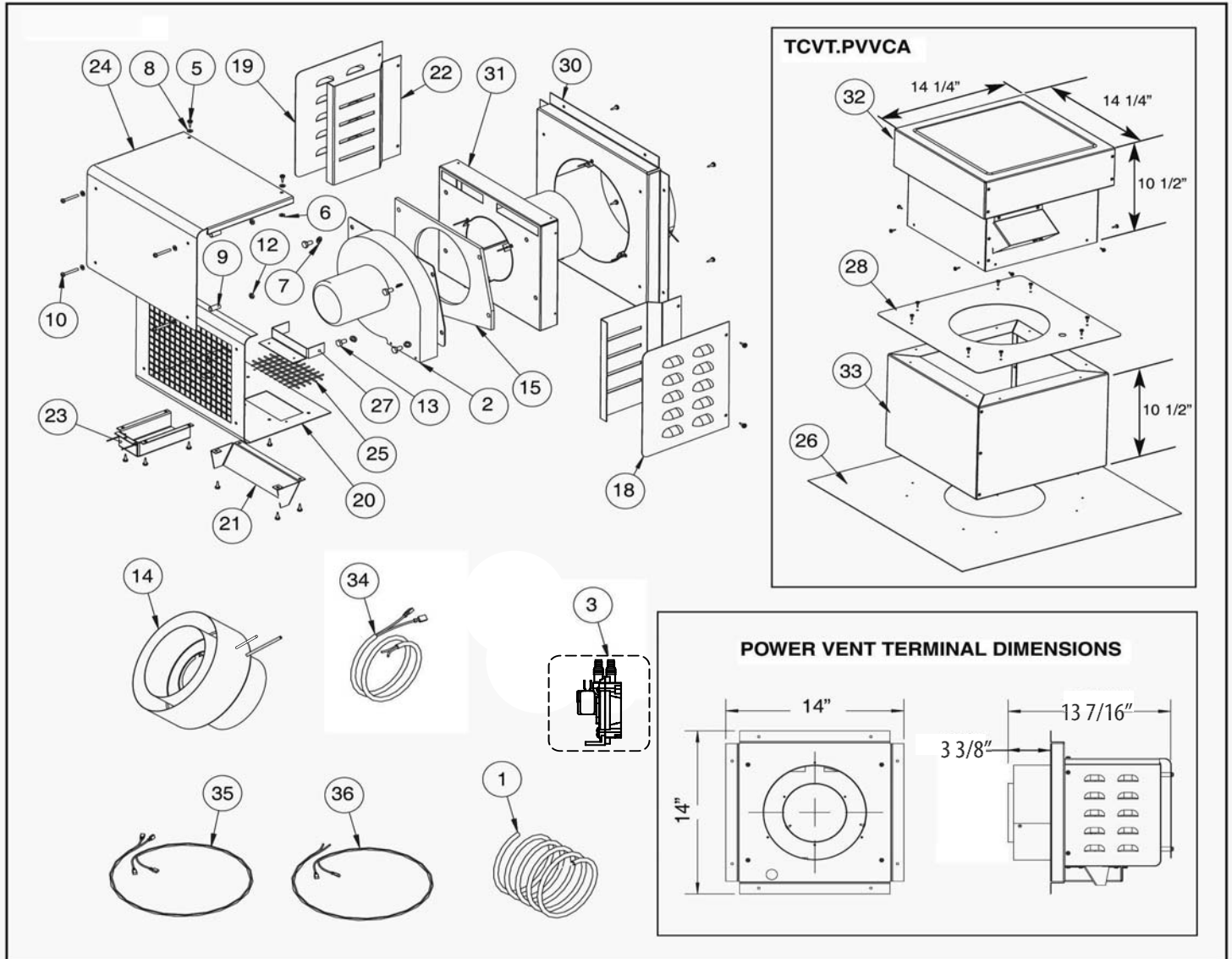

# Venting Components

## SIMPSON DURAVENT COMPONENTS

Number	Description
1208	6" Pipe Length
1207	9" Pipe Length
1206	12" Pipe Length
1204	24" Pipe Length
1203	36" Pipe Length
1202	48" Pipe Length
1211	11" to 14-5/8" Pipe, Adjustable
1217	4-10" Pipe, Adjustable
1245	45° Elbow
1290	90° Elbow
1240	Round Ceiling Support /Wall Thimble Cover
1241	Cathedral Ceiling Support Box
1242	Wall Firestop
1247	Wall Thimble
1263	Ceiling Firestop
1288	Wall Strap

## SECURE VENT COMPONENTS

Number	Description
SV5L6	6" Pipe Length
SV5L12	12" Pipe Length
SV5L24	24" Pipe Length
SV5L36	36" Pipe Length
SV5L48	48" Pipe Length
SV5LA	6" Pipe, Adjustable
SV5LA12	12" Pipe, Adjustable
SV5LA24	24" Pipe, Adjustable
SV5E45	Swivel 45° Elbow
SV5E90	Swivel 90° Elbow
SV5CSB	Adjustable decorative sq. cathedral support
SV5AC	Collar for decorative sq. cathedral support
SV5SU	Universal support
SV5SD	Floor support
SV5BM	Wall band
SV5RSA	Attic radiation shield
SV5RSM	Wall radiation shield
SV5BF	Firestop

## SELKIRK DIRECT-TEMP

Number	Description
1605006	6" Pipe Length
1605009	9" Pipe Length
1605012	12" Pipe Length
1605018	18" Pipe Length
1605024	24" Pipe Length
1605036	36" Pipe Length
1605048	48" Pipe Length
1605082	4-10" Pipe, Adjustable
1605215	45° Elbow
1605230	90° Elbow
1605424B	Cathedral ceiling support box (blk)
1605500	Firestop spacer
1605460B	Wall thimble (blk)
1605430	Wall support band

## ICC MODEL EXCELDIRECT

Number	Description
TC-5DL6	6" Pipe Length
TC-5DL1	12" Pipe Length
TC-5DL2	24" Pipe Length
TC-5DL4	48" Pipe Length
TC-5DLF	36" Flexible Length
TC-5DLT	12" Pipe, Adjustable, Galvalume
TE-5DE45	Swivel 45° Elbow, Galvalume
TE-5DE90	Swivel 90° Elbow, Galvalume
TM-5SS	Square Support / Radiation Shield
TM-5RDS	Round Support / Radiation Shield
TM-5CS	Cieling Support / Firestop
TM-OS	Offset Support
TM-SR	Roof Support
TM-WS	Adjustable Wall Support
TM-5WT	Insulated Wall Thimble
TM-5TR	Trim Ring, Black
TM-5AS	Attic Radiation Shield / Firestop



TOWN & COUNTRY  
FIREPLACES™

**TECHNICAL SUPPORT: (250) 748-1184**  
**[www.townandcountryfireplaces.net](http://www.townandcountryfireplaces.net)**  
**2975 Allenby Rd., Duncan, BC V9L 6V8**