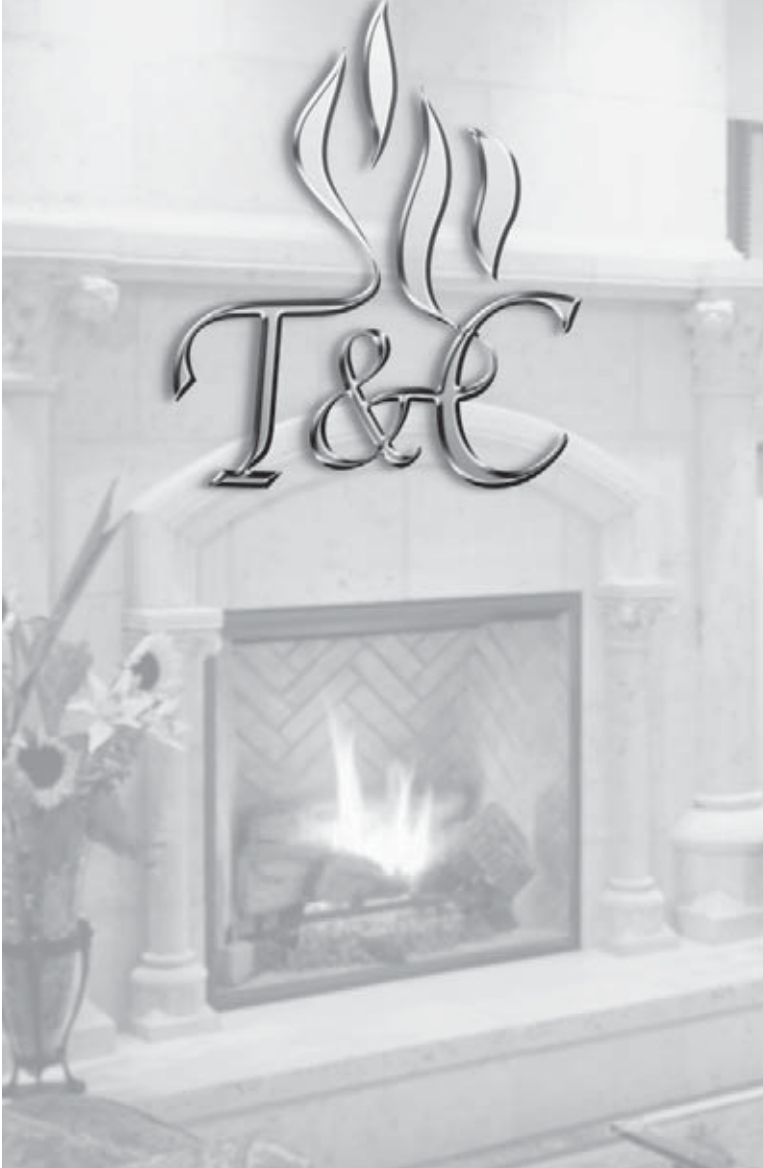


**IMPORTANT:
THESE INSTRUCTIONS ARE TO REMAIN
WITH THE HOMEOWNER**

These instructions are supplementary to the Installation and Operating Instructions supplied with the fireplace and should be kept together. Refer to the Installation and Operating Instructions for proper gas supply, safety requirements and operating instructions.



**TOWN & COUNTRY
FIREPLACES™**

**TC54
COUNTRY HOME
BURNER KIT
TC54.NG02.C**

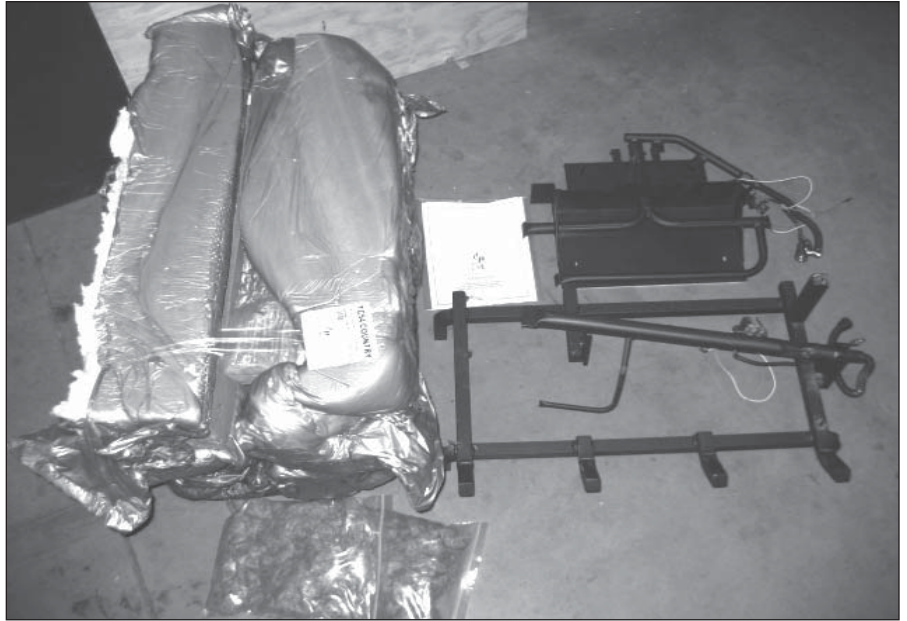


**PART#
TC54.NG02.C
FOR TC54**



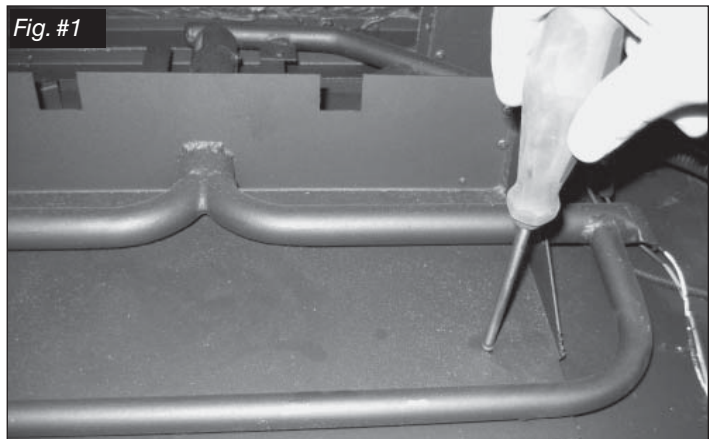
Package Contents

- BURNER ASSEMBLY (including pilot and manifold)
- LOG GRATE (including upper burner and pilot assembly)
- EMBER MATERIAL (two bags)
- HARDWARE PACKAGE



Burner / Grate Installation

1. Attach the lower burner assembly to the floor of the firebox with two screws. (Fig. # 1)



2. Attach the manifold supply tube from the lower burner to the front bulk head fitting and tighten. (Fig. # 2) Ensure that there are no leaks.

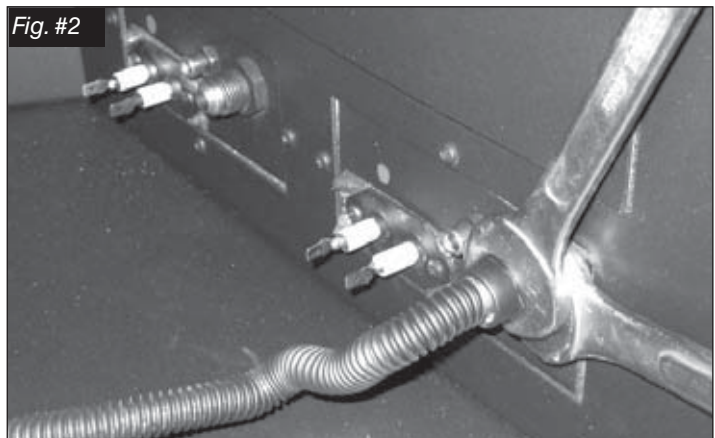
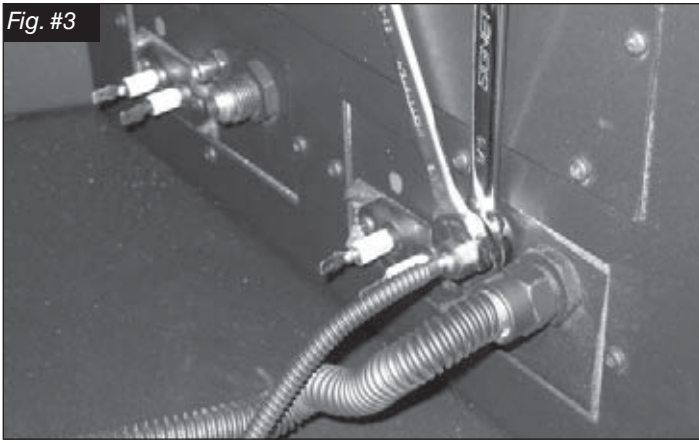
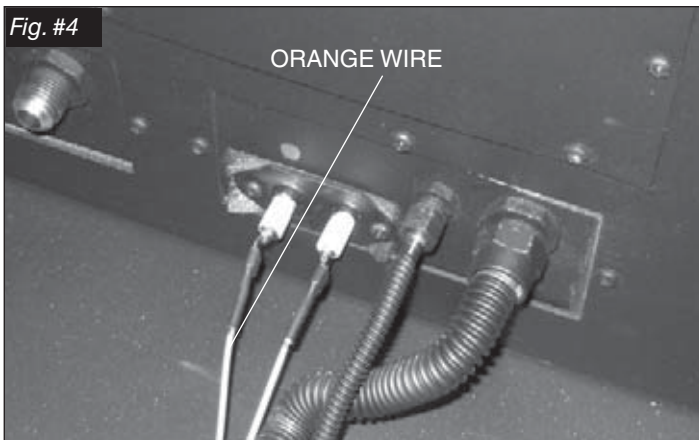


Fig. #3



3. Attach the pilot supply tube from the lower burner pilot to the front bulk head fitting and tighten. (Fig. # 3) Ensure there are no leaks.

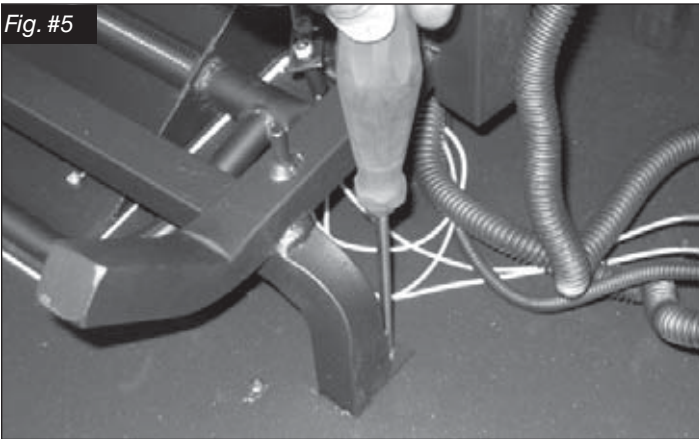
Fig. #4



4. Attach spark electrode (ORANGE) and sensor leads from lower burner pilot to the front electrical bulk head. (Fig. # 4) (The spark electrode connection has a red dot above it)

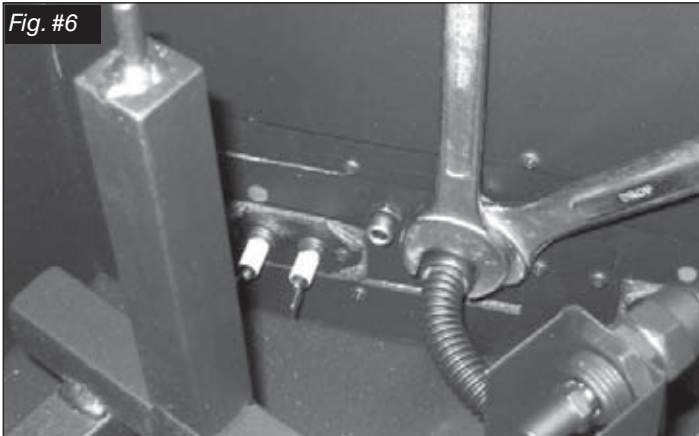
A panel set must now be installed. See Installation and Operating Instructions manual for details.

Fig. #5



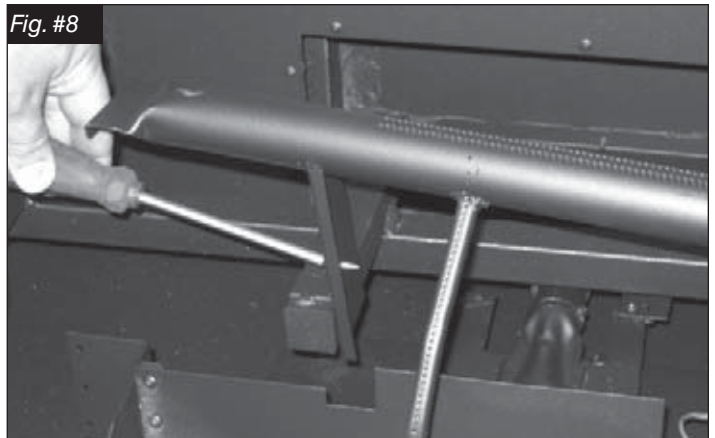
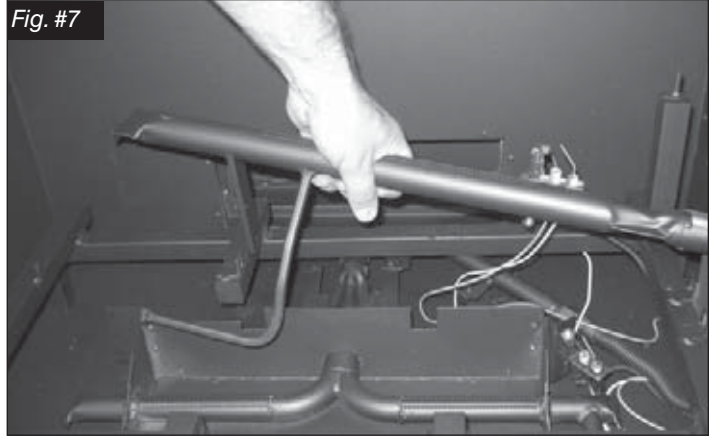
5. Position the grate and attach it to the floor with two screws located behind the front legs. (Fig. # 5)

Fig. #6

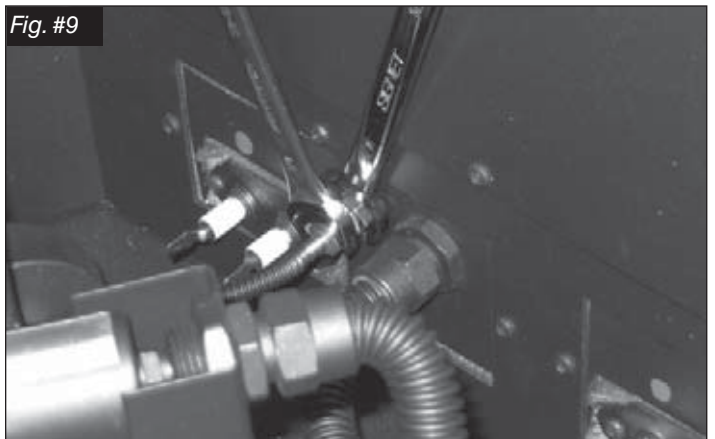


6. Attach the manifold supply tube from the upper burner to the rear bulk head fitting and tighten. (Fig. # 6) Ensure that there are no leaks.

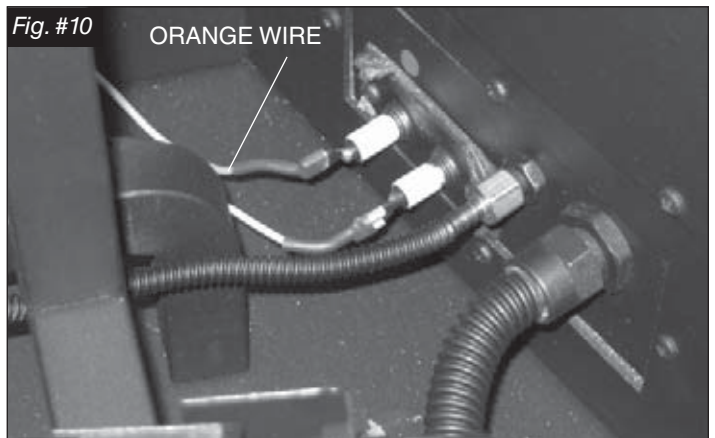
7. Install the upper burner/ pilot assembly. Ensure that the orifice engages fully into the burner and that **the shutter is fully closed for natural gas or fully open for propane.** (Figs. #7 and 8)



8. Attach the pilot supply tube from the upper burner pilot to the rear bulk head fitting and tighten. (Fig. # 9) Ensure there are no leaks.



9. Attach spark electrode (ORANGE) and sensor leads from upper burner pilot to the rear electrical bulk head. (Fig. # 10) (The spark electrode connection has a red dot above it)



Propane Conversion

If the unit is to be used on propane convert as follows using the components supplied with this fireplace:

WARNING

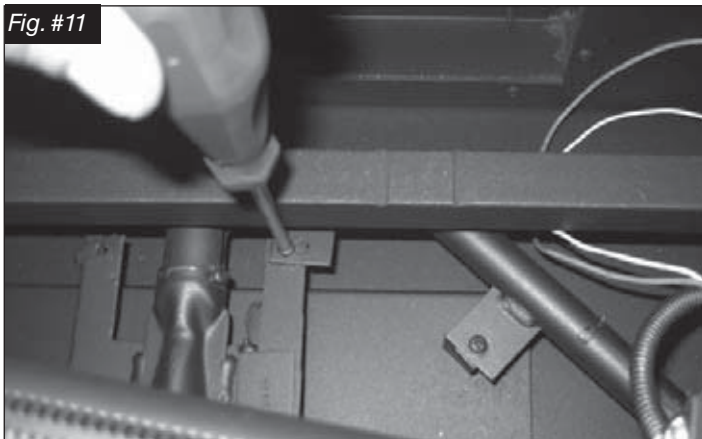
This conversion kit shall be installed by a qualified service agency in accordance with the manufacturer's instructions and all applicable codes and requirements of the authority having jurisdiction. If the information in these instructions is not followed exactly, a fire, explosion or production of carbon monoxide may result causing property damage, personal injury or loss of life. The qualified service agency is responsible for the proper installation of this kit. The installation is not proper and complete until the operation of the converted appliance is checked as specified in the manufacturer's instructions supplied with the kit.

CAUTION

The gas supply and electrical power shall be shut off before proceeding with the conversion.

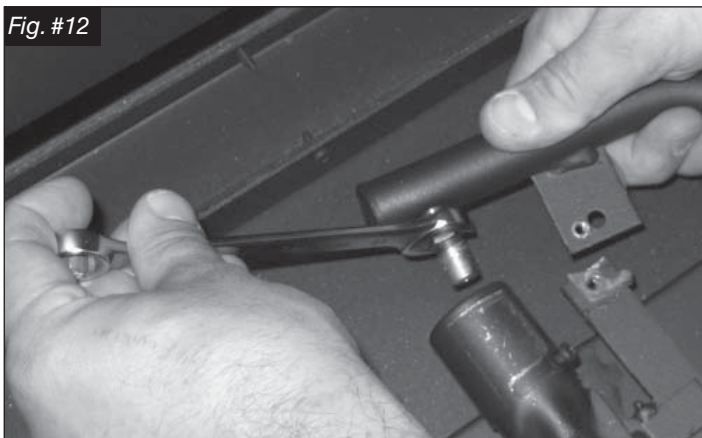
Note: Factory supplied components must be used to ensure correct input. After conversion confirm proper manifold pressure.

Fig. #11



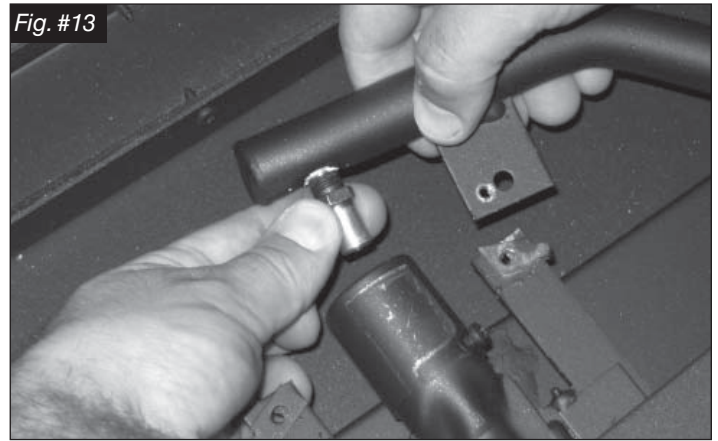
1. Ensure the burners, pilots and gas supply are turned off, and the appliance has cooled.
2. Remove the two screws securing the manifold assembly to the lower burner, (Fig. #11)

Fig. #12

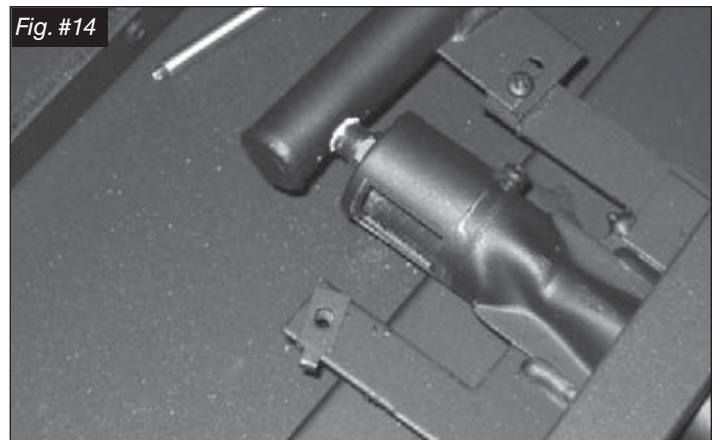


3. Using a 1/2" wrench, undo the natural gas burner orifice, (marked #28). (Fig. #12)

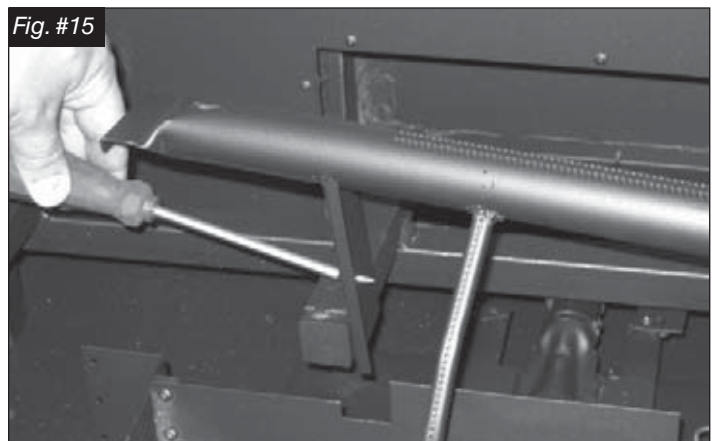
4. Apply a small amount of pipe joint compound to the threads of the propane burner orifice (marked #43) to ensure a good seal, before screwing it into the fitting. (Fig. #13)



5. Open shutter fully. (Fig. #14)
6. Reinstall the manifold to the lower burner using the screws previously removed.



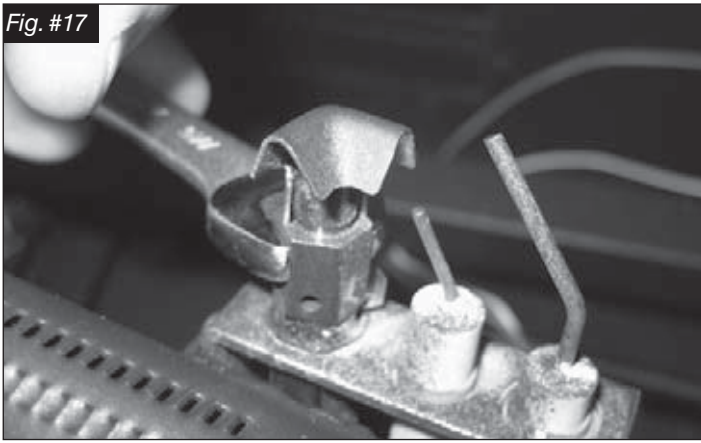
7. Remove the screw securing the upper burner to the grate assembly. (Fig. #15)



8. Using a 1/2" wrench, undo the natural gas burner orifice, (marked #28). (Fig. #16)
9. Apply a small amount of pipe joint compound to the threads of the propane burner orifice (marked #43) to ensure a good seal, before screwing it into the fitting.
10. Open shutter fully.
11. Reinstall the upper burner to the grate assembly and secure in place using the screw previously removed.

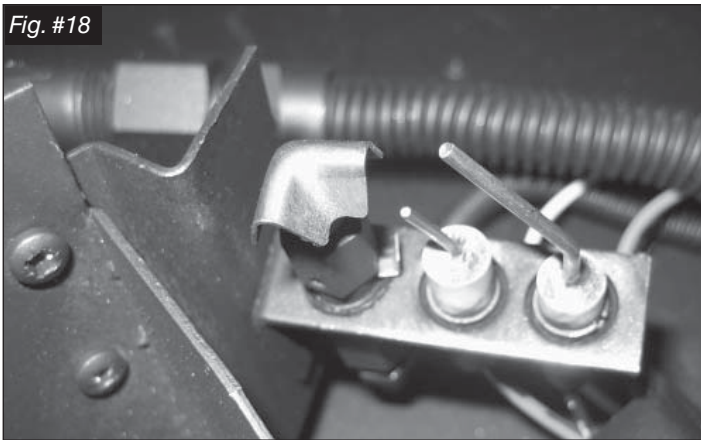


Fig. #17



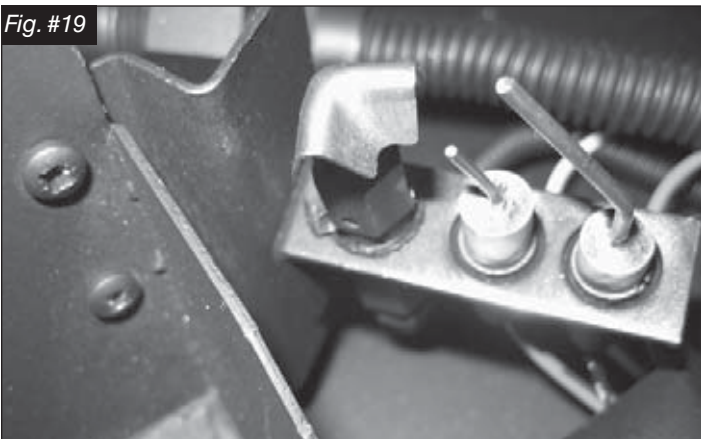
12. With a 7/16" wrench loosen the pilot head on the pilot assembly attached to the lower burner assembly (Fig. #17)

Fig. #18



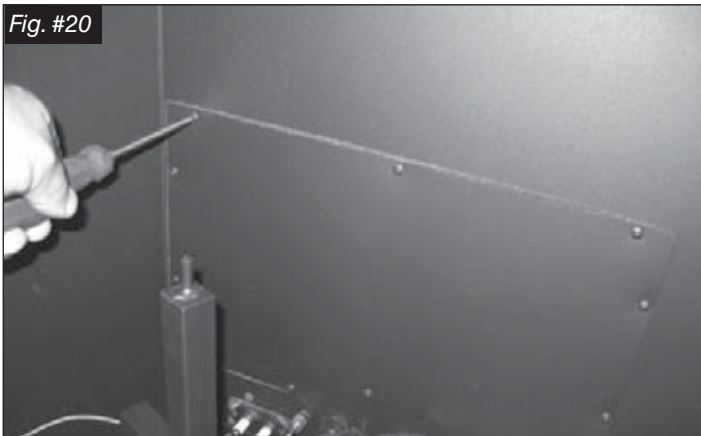
13. Slide the pilot adjustment band over and ensure that the hole in the orifice band is showing. (Fig. #18 indicates NG position, Fig. #19 indicates LP position)

Fig. #19



14. Repeat the conversion on the pilot attached to the upper burner.

Fig. #20

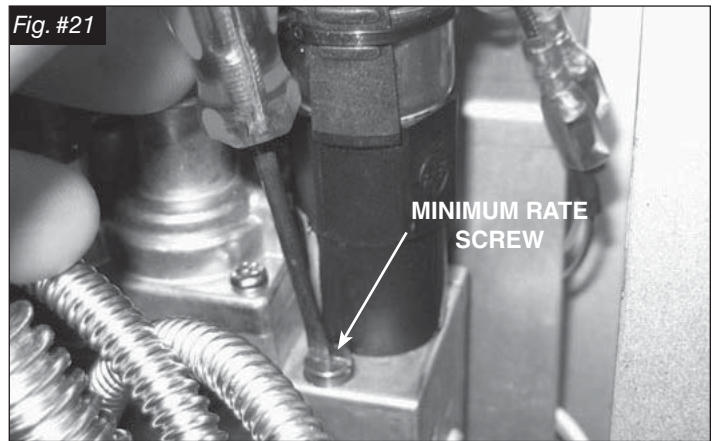


15. Remove access panel, 10 screws, and set aside. (Fig. #20)

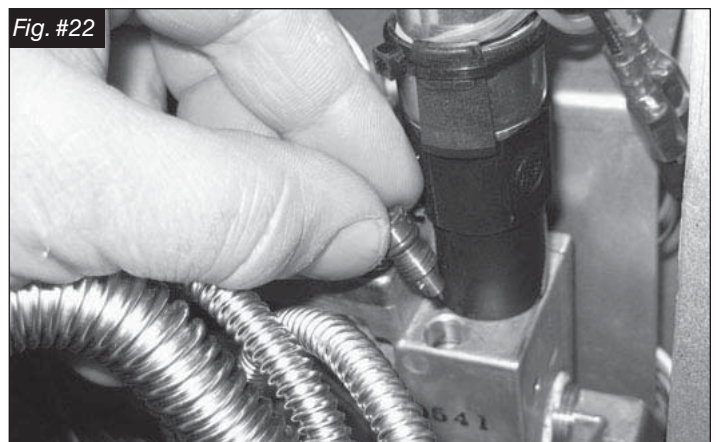
16. Remove the minimum rate screw located in each valve.
(Fig. #21)

REMOVING THE MINIMUM RATE SCREW

The minimum rate screw is sealed with an o-ring near the bottom of the screw. Use a thin bladed screwdriver to back the screw out to the limit of the threading. At this point, a groove on the screw body will be visible just above the valve body. Insert a thin tool (knife blade or fine screwdriver blade) into the groove and gently pry the screw up. It helps to rotate the screw while lifting on it.



17. Replace the minimum rate screw with the one provided in the propane conversion kit supplied with this fireplace. Ensure that the screws are fully seated. (Fig. #22)



18. Pull off the rubber cap from the top of the pressure regulator.
(Fig. # 23)

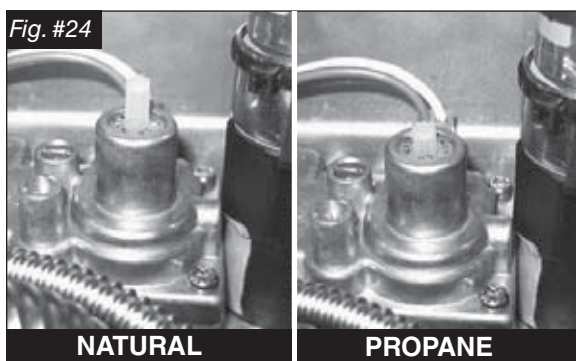
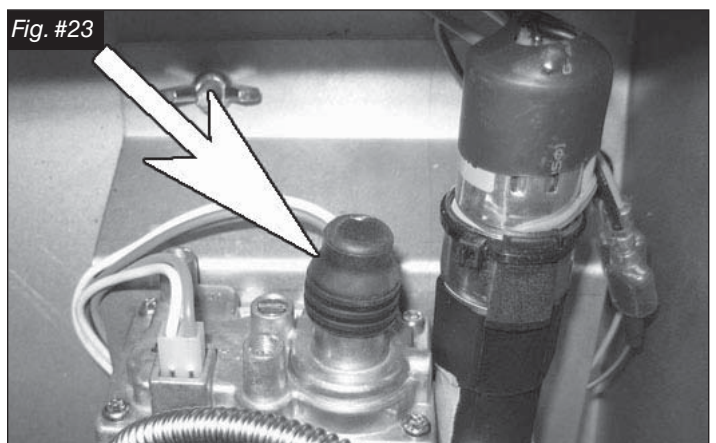
19. Press down on the center post and rotate 90°. The center post should stay down. (Fig. #24). Replace the rubber cap.

20. Repeat the pressure adjustment on the other valve.

21. Fill in the date and the name of the person who performed the conversion in the white area on the conversion label. Peel off the protective backing and apply the conversion label directly over the gas specifications on the rating label.

22. Attach the access panel to the side of the firebox with the previously removed screws. (Fig. #25)

Note: Gasket must be installed with access panel.



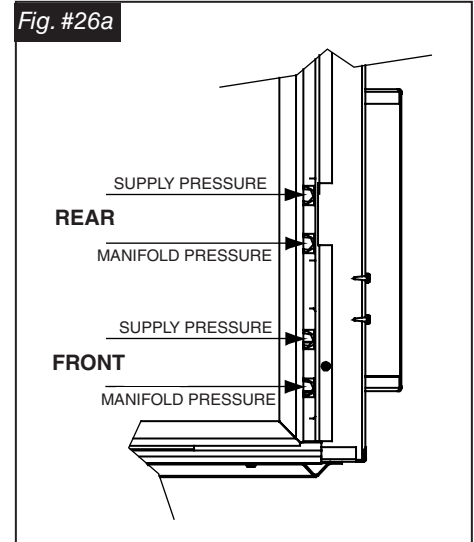
Gas Pressure Check

Note: To test the gas pressure, turn off the gas supply before removing the blanking plug from the supply pressure test port or manifold pressure test port.

There are four ports on this fireplace the top two are connected to the rear burner and the bottom two are to the front burner. Manifold pressures should be checked on both to ensure they are correct.

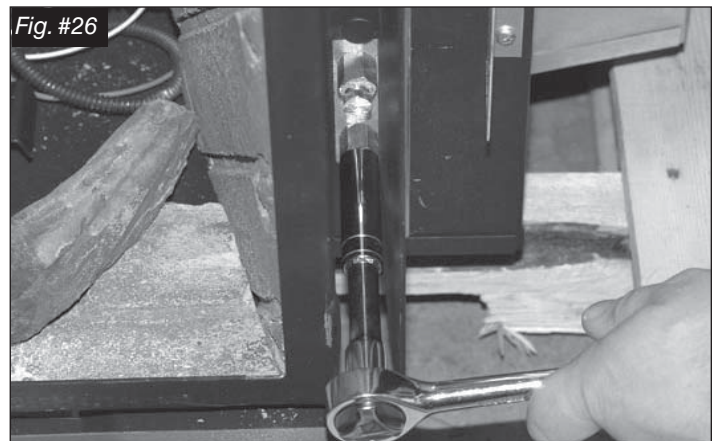
Verify gas pressures with the fireplace lit and on the highest setting.

1. Remove the blanking plug from the pressure test port. The plug is located between the right side lintel and firebox side. (Fig. # 26 & 26a)



CORRECT GAS PRESSURE REQUIREMENT:

Supply Pressure	Natural Gas	Propane
Minimum	5.0" wc	12.5" wc
Maximum	13.9" wc	13.9" wc
Manifold Pressure		
Maximum	3.8" wc	11.0" wc
Minimum	2.1" wc	5.5" wc



2. Thread the extension test fitting into the open test port. (Fig. # 27)
3. Attach a pressure gauge onto the fitting.
4. When testing is complete, shut off the gas, remove the fitting and replace the blanking plug. Thread sealant will be required to ensure a gas tight connection.



Ember Material

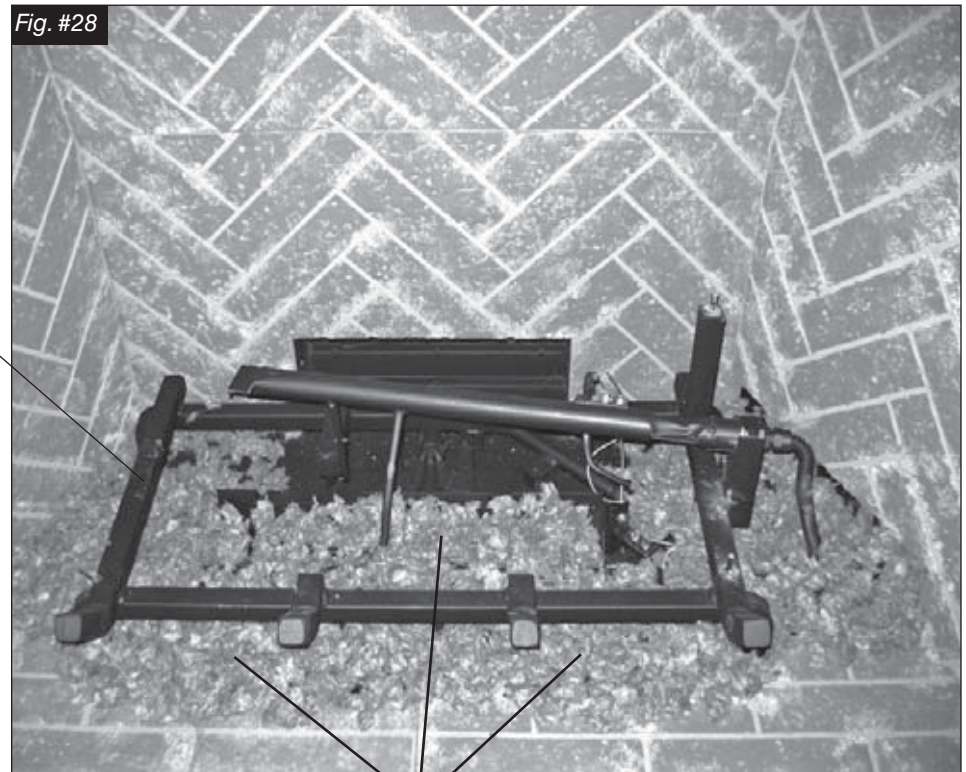
Two bags of ember material is shipped with the fireplace and need to be installed to ensure optimum performance and flame appearance.

Pull apart the material into ember size pieces (approximately 1" squares) and gently place them into the lower burner pan. Do not compress, leave it loose for best performance. Fill the lower burner pan level with the top of the pan at rear, and gradually slope forward to the firebox floor, covering both lower burner tubes. Place remaining ember material outside of the burner pan as desired to cover-up gas lines and brackets.

Note: Ember material placement and amount will affect flame appearance. More ember material results in lower flame height. Add or remove as needed until desired flame affect.

Do not place any ember material on the upper burner tube.

Ember Material Placement



LOG GRATE

GLOWING EMBERS

Log Set Assembly

The logs are packaged in a foam pack inside the box, and are fragile, and should be handled with care. Unpack and inspect log set. There should be a total of seven logs. Gas plumbing and vent connections should be completed before proceeding.

Position the logs exactly as indicated by the following pictures. The three main logs have holes and / or pins. Engage each pin in the corresponding holes. The four smaller logs do not have holes or pins. They rest in position. Locate as per the diagrams (Fig. # 29-35)

Note: Improper placement of logs will cause sooting on internal parts and glass. The logs may need to be repositioned slightly to avoid excessive flame impingement.

Fig. #29

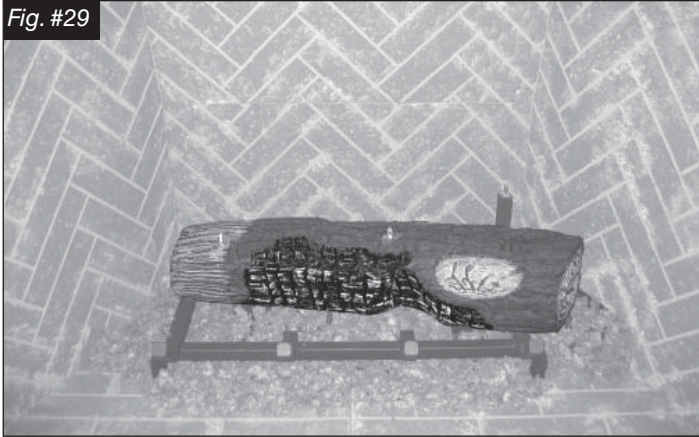


Fig. #31



Fig. #30

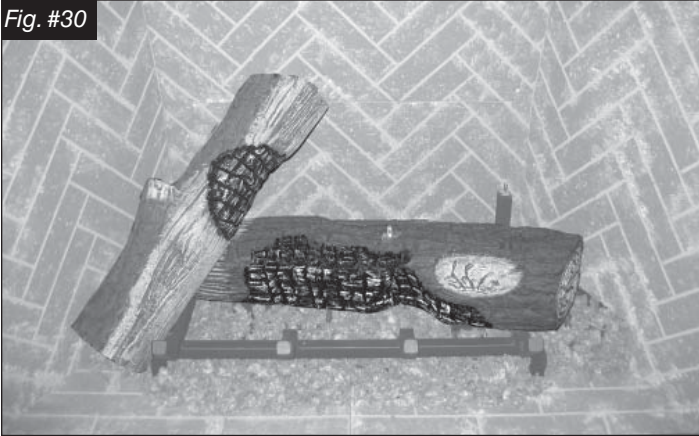


Fig. #32



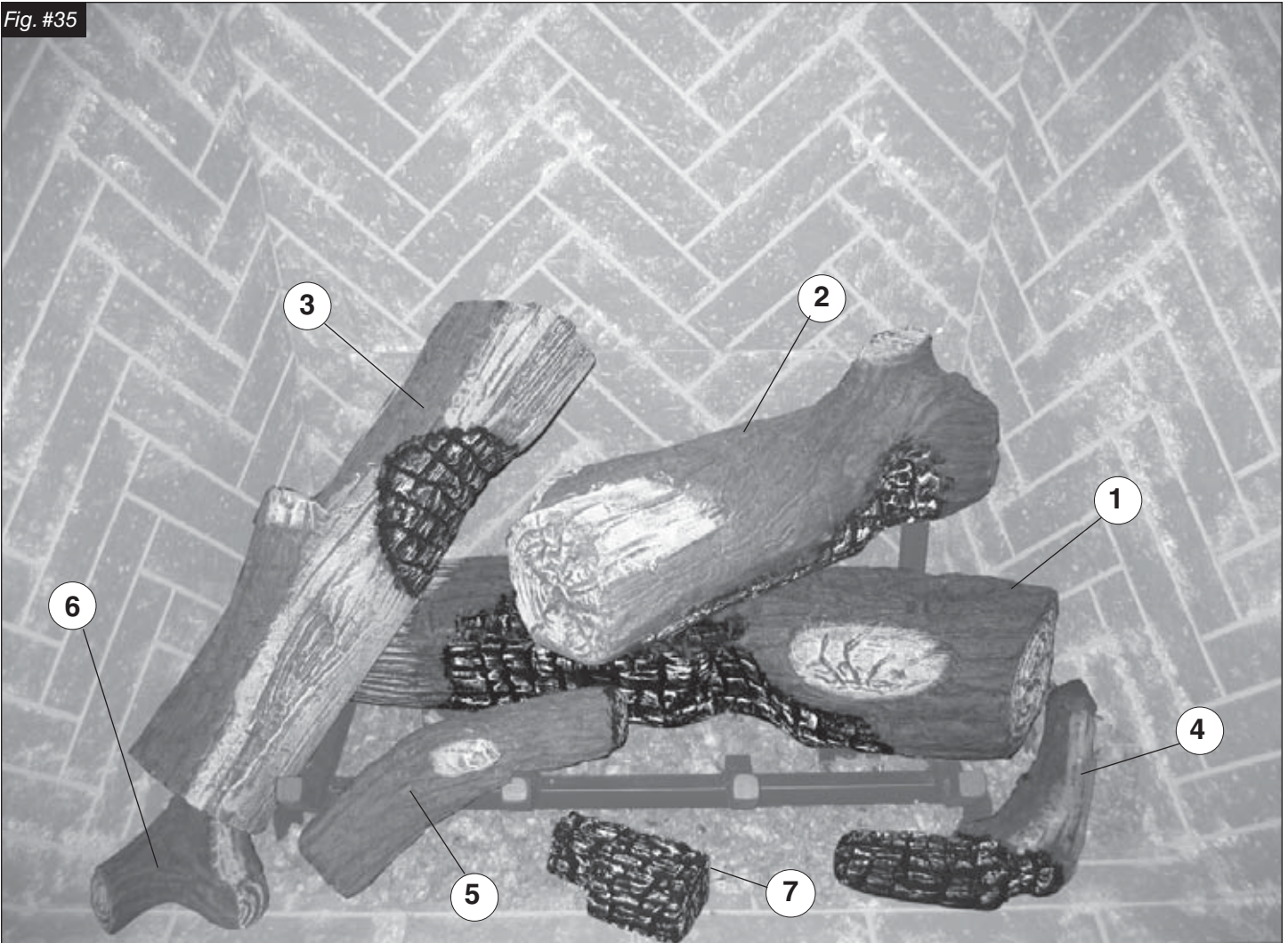
Fig. #33



Fig. #34



Fig. #35



Burner Flame Adjustment

An air shutter on each of the burner tubes controls the primary combustion air to the gas burner and is preset closed at the factory for natural gas fuel. Some adjustment may be necessary to obtain desired flame and to eliminate carbon deposits. Evaluate flame appearance after the fireplace has reached operating temperature. See Fig. #36 for proper flame pattern.

Open primary air shutter if the logs, glass, and firebox have carbon accumulation and / or the flames are long, dark and stringy. The shutter may also be opened to enhance the Ember Material glow and lessen the flame height.

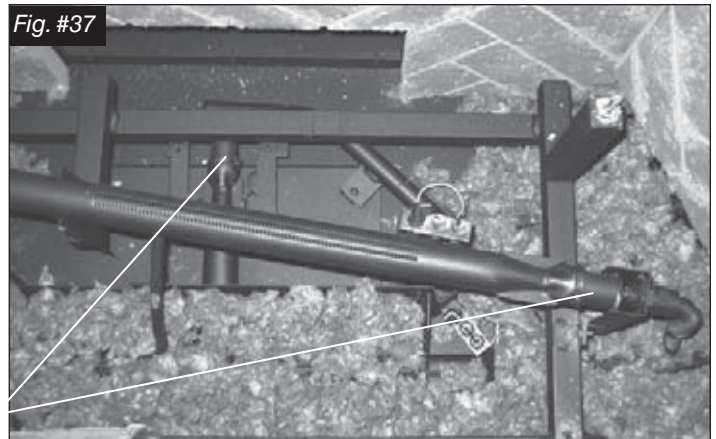
Caution: Burner area may be hot!

Turn off the fireplace and allow the unit to cool before proceeding.

To Adjust: (See Fig. # 37)

1. Open and remove window frame and set aside. See "Window Frame Removal" section found in the Installation and Operating Instructions manual.
2. Remove the logs and set aside.
3. Loosen the screw in the Primary Air Shutter.
4. Rotate the shutter to increase or decrease the amount of primary air.

PRIMARY AIR SHUTTERS



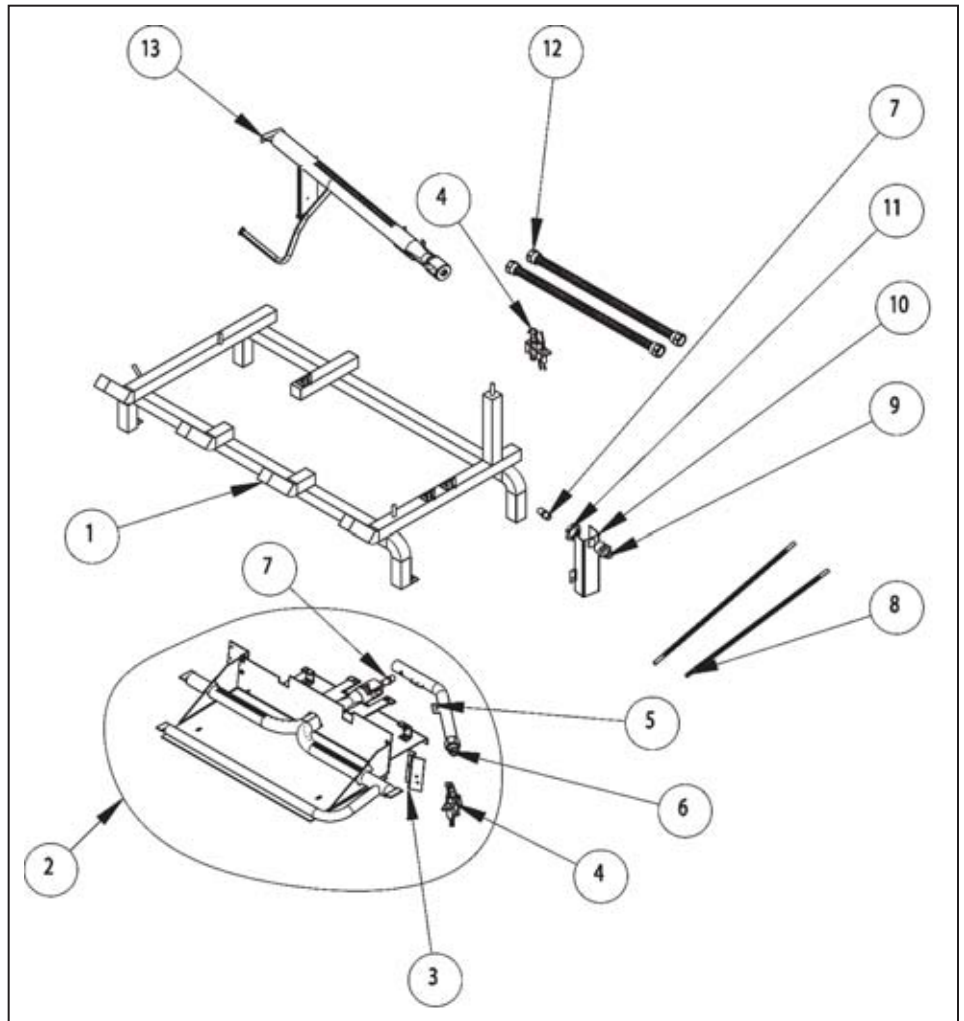
The flame should be just orange and "lazy". It should NEVER be set to create soot on internal parts and glass.



Replacement Parts

ITEM	DESCRIPTION	PART NO.
1	LOG GRATE ASSEMBLY	TC54.8181
2	LOWER BURNER ASSEMBLY	TC54.90859
3	PILOT BRACKET	9279.002
4	PLOT ASSEMBLY	5005.025
5	MANIFOLD WELDED ASSEMBLY	TC42.90881WLD
6	FITTING, DORMONT, BURNER SUPPLY	5019.221
7	ORIFICE (NG) #28	5022.14
	ORIFICE (LP) #43	5021.32
8	FLEX, 1/4" LINE , DORMONT	5019.225
9	FITTING, ORIFICE INLET	5019.21
* 10	UPPER BURNER BRACKET	8187.5
11	1/2-14NPT BRASS LOCKNUT	5021.01
12	FLEX, 1/2" LINE , DORMONT	5019.223
13	BURNER, TC54, REAR	5011.8302
	LOG SET, COMPLETE	5098.74615
	REAR, #1 (shown in fig.#35)	5098.74615.1
	RIGHT, #2 (shown in fig.#35)	5098.74615.2
	LEFT, #3 (shown in fig.#35)	5098.74615.3
*	BOTTOM RIGHT, #4 (shown in fig.#35)	5098.74615.4
	BOTTOM CENTRE, #5 (shown in fig.#35)	5098.74615.5
	BOTTOM LEFT, #6 (shown in fig.#35)	5098.74615.6
	MIDDLE, #7 (shown in fig.#35)	5098.74615.7

*Sold only in sets



Notes



TOWN & COUNTRY
FIREPLACES™

TECHNICAL SUPPORT: 1-877-715-2664
www.townandcountryfireplaces.net
2975 Allenby Rd., Duncan, BC V9L 6V8