

OPTIONAL POWER VENT KIT



TOWN & COUNTRY
FIREPLACES™

TCVT.PVA INSTALLATION AND OPERATING INSTRUCTIONS

For use with Series "B"
Town and Country Fireplaces
Equipped with Electronic controls

EACH KIT CONTAINS:

ITEM	PART No.	DESCRIPTION	QTY.
1	TCVT.502461	Power vent terminal	1
2	5096.813	Venting adaptor	1
3	TCVT.506251	Blower wiring	1
4	TCVT.506271	Pressure switch wiring	1
5	TCVT.507156	On/Off switch wiring	1
6	9072.7	Pressure switch clip	1
7	5027.1	Pressure switch	1
8	5071.5	On/Off switch	1
9	5004.085	Tubing, TYSC-516316-100	1
10	9079.01	Receptacle box	1
11	5093.01	Hose Clamp	2

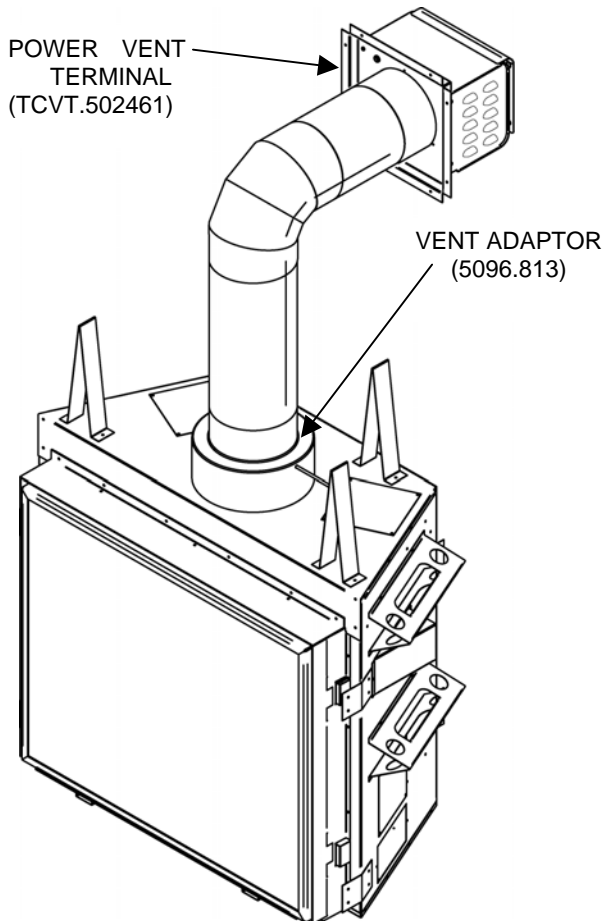

**IMPORTANT:
THESE INSTRUCTIONS ARE TO REMAIN WITH
THE HOMEOWNER**



POWER VENT INSTALLATION

Locate the fireplace and control box as per the main instructions supplied, and then make the following modifications to add the components used with the power vent kits. This Kit can only be used in conjunction with the Electronic control versions of Town and Country fireplaces. This installation must conform with local codes or, in the absence of local codes, with the Natural Fuel Gas Code, ANSI Z223.1/NFPA 54, or the Natural Gas and Propane Installation Code, CSA B149.1.

VENTING

This kit uses either Simpson DuraVent GS direct vent pipe or Secure Vent direct vent pipe with a 5" inner pipe and an 8" outer pipe. For part numbers see the table of venting components on page 7 of this manual.

- 1) Locate the power vent termination as per the following clearance to combustibles table, venting configuration diagram (fig#1), and terminal location diagram (fig#2).
- 2) Cut and frame an 11"x11" opening, the center of the square hole should line up with the centerline of the horizontal pipe.
- 3) Install the Simpson DuraVent Wall thimble, part number 1247(not supplied with kit), in the opening to retain any insulation in the wall and maintain proper clearances. If the wall being penetrated is constructed of noncombustible material only, i.e. masonry block or concrete, the wall thimble is not required and a hole with zero clearance is acceptable (8" hole).
- 4) Attach the terminal to the outside wall. Ensure that the terminal is the right way up and that only the outer flanges, that are used to secure the terminal to the building, are covered by the exterior wall or siding.
Note: No other part of the terminal can be recessed into the exterior wall or siding.
- 5) Attach the vent adaptor directly to the appliance with three screws and seal outer pipe with aluminum tape provided. Note the inner pipe need not be sealed, see fig # 3.
- 6) Connect the high temperature silicone tube to the vacuum pressure tapping on the adaptor, secure with the hose clamp provided and route the tube through any hole, back to control box. Tube may touch unit and be trimmed if required. **Note: ensure that there are no blockages in this tube, as this will cause the control to fail to operate.**
- 7) Run the required Simpson DuraVent GS / Secure Vent pipe from the adaptor to the terminal assembly. Assemble as per the vent pipe manufacturer's instructions.

FAN WIRING

The power vent terminal is supplied with a 3 foot long high temperature rated (250°C / 482°F) wire lead; this wire must not be replaced by standard wire due to the high temperatures inside the assembly. A junction box must be provided outside of the terminal to connect to the high temperature wire. Run 14/2 wire from the junction box to the fireplace control box. **This appliance must be electrically grounded in accordance with local codes, or in the absence of local codes, with the National Electrical Code ANSI/NFPA 70, or the Canadian Electrical Code, CSA C22.1.**

Minimum Clearances to Combustibles:

Vertical vent pipe: 1-1/2 in. (38 mm)

Horizontal vent pipe:

Top 1-1/2 in. (38 mm)
Sides 1-1/2 in. (38 mm)
Bottom 1-1/2 in. (38 mm)

All other clearances are as per fireplace installation instructions.

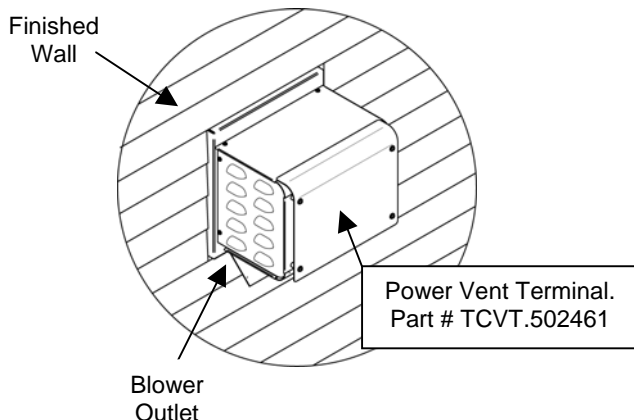

POWER VENT SYSTEM SCHEMATIC

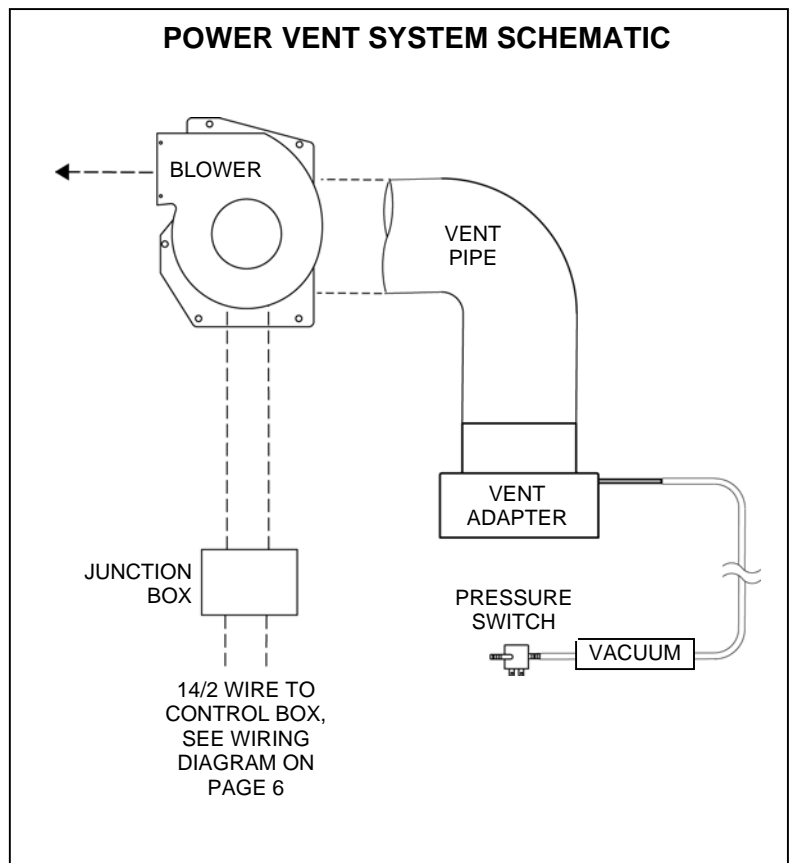
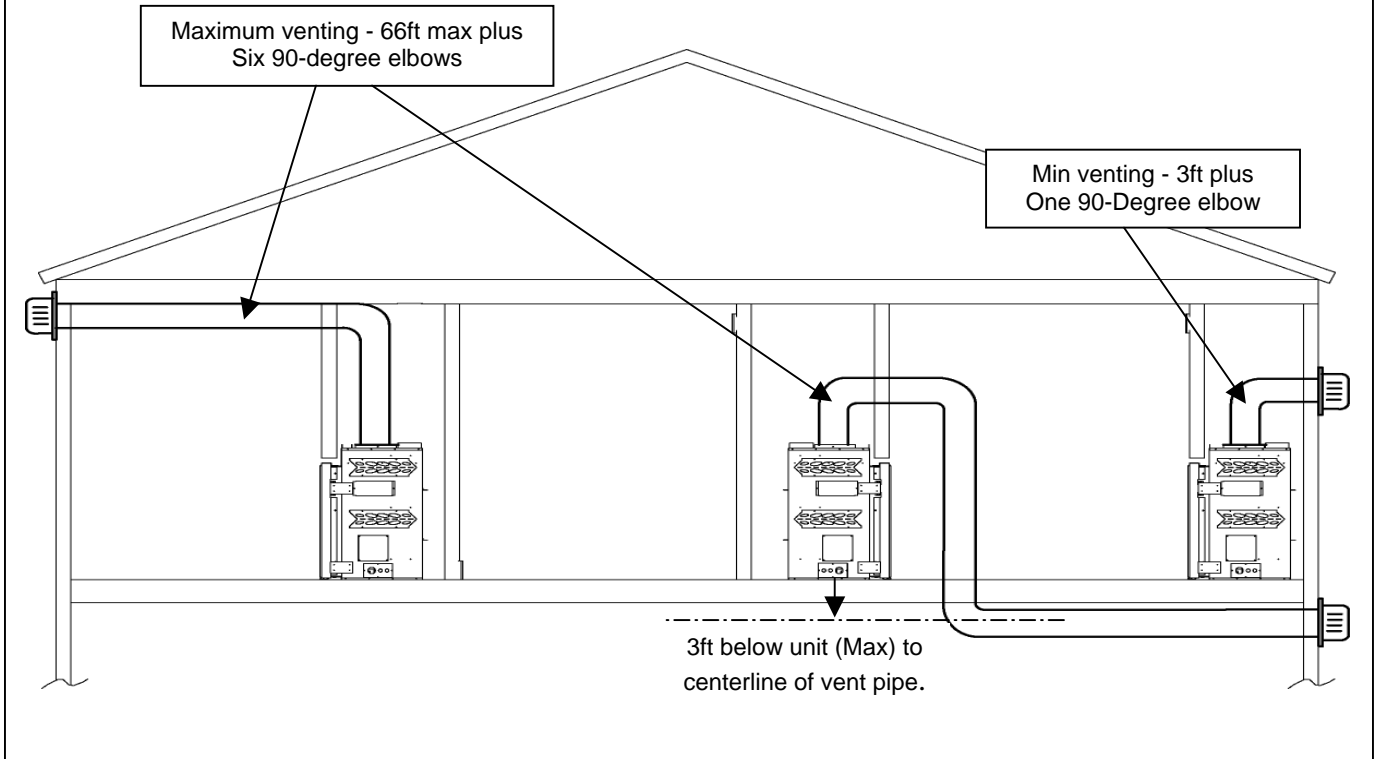

Fig. #1

VENTING CONFIGURATIONS

Maximum vent length is 66ft plus six 90-degree elbows or combination of other elbows equaling 90-degrees, minimum vent length is 3ft plus one 90-degree elbow. The vent must be vented through a sidewall, with any combination of rise and run between the above figures including up to 3ft below the unit. Ensure Vent pipe is properly supported.



WALL TERMINATION VENTING CHART

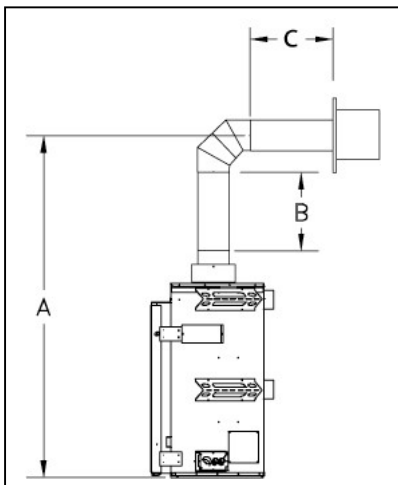

A			B	C	
Min. Rise			Pipe length	Max. Pipe length	Min. Pipe length
TC36B*	TC42B	TC36ST			
51"	57"	56"	0"	66 feet	3 feet
63"	69"	68"	12"	65 feet	2 feet
75"	81"	80"	24"	64 feet	1 foot

*TC36B and TC36AR have the same dimensions

Fig. #2

VENT TERMINAL MINIMUM CLEARANCES

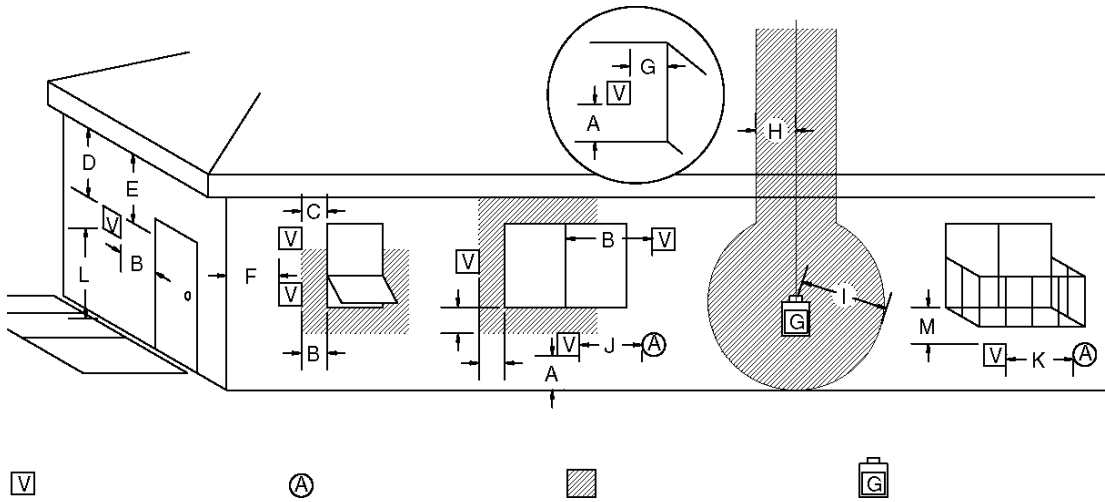

- A= Clearances above grade, veranda, porch, deck, or balcony [* 12 inches (30 cm) minimum]
- B= Clearance to window or door that may be opened [* 12 inches (30 cm) minimum]
- C= Clearance to permanently closed window [minimum 12 inches (30 cm) recommended to prevent condensation on window]
- D= Vertical clearance to ventilated soffit located above the terminal within a horizontal distance of 2 feet (60 cm) the center-line of the terminal [12 inches (30cm) minimum]
- E= Clearance to unventilated soffit [12 inches (30cm) minimum]
- F= Clearance to outside corner [6 inches (15 cm) minimum]
- G= Clearance to inside corner [6 inches (15 cm) minimum]

- H= *Not to be installed above a meter/ regulator assembly within 3feet (90cm) horizontally from the centerline of the regulator.
- I= Clearance to service regulator vent outlet [*6feet (1.8m) minimum]
- J= Clearance to non-mechanical air supply into building or combustion air inlet to any other appliance [*12 inches (30cm) minimum]
- K= Clearance to a mechanical air supply inlet [*6 feet (1.8m) minimum]
- L= ^Clearance above paved sidewalk or paved driveway located on public property [*7 feet (2.1m) minimum]
- M= Clearance under veranda, porch, deck, or balcony [12 inches (30cm) minimum**]

^ A vent shall not terminate directly above a sidewalk or paved driveway, which is located between two single family dwellings and serves both dwellings*

** Only permitted if veranda, porch, deck, or balcony is fully open on a minimum of 2 sides beneath the floor*

* As specified in CGA B149 Installation Codes, Note: local Codes or Regulation may require different clearances

* For U.S.A. Installations follow the current National Fuel Gas Code, ANSI Z223.1

Fig. #3

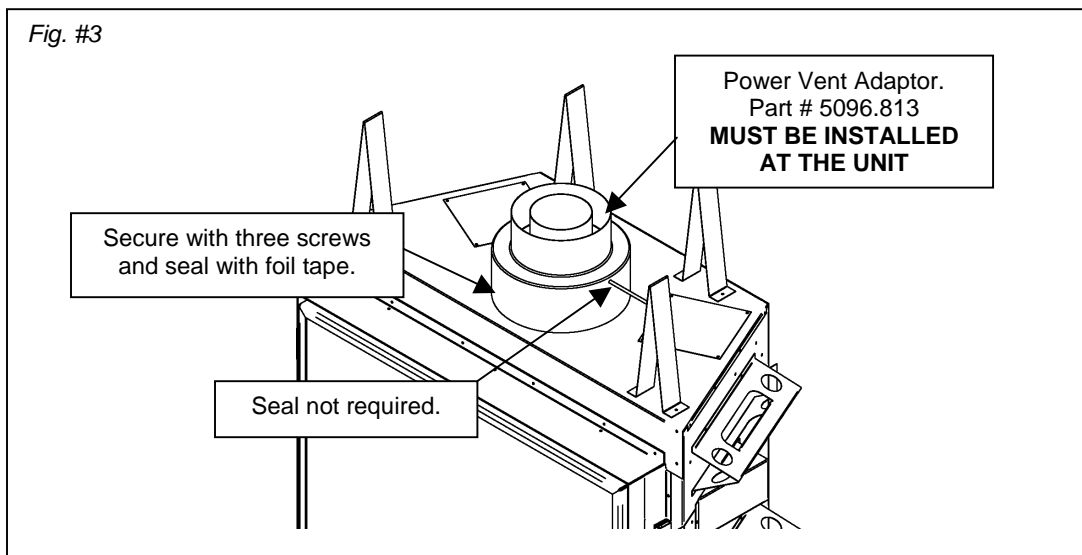

CONTROL BOX MODIFICATIONS

- 1) Remove window frame latch tool and set aside.
- 2) Remove 4 screws holding control panel in place and carefully lift off over the control knob.
- 3) Disconnect leads from the burner on/off switch and remove switch from control panel. Install the double pole switch supplied with the kit. The new switch has 4 wire connection tabs, two left and two right. One side operates the power vent blower; the other side operates the burner control system.
- 4) Disconnect the battery pack red and black wires from the control system and remove the batteries and battery pack from the control box. **The Power Vent system only works on AC power.**
- 5) Connect one end of the pressure switch wire lead to the pressure switch. Attach the pressure switch clip to the bottom left screw of the valve-mounting bracket and secure the pressure switch in place, see fig #4.
- 6) Connect the opposite end of the pressure switch wire, one lead to the burner on/off switch and the other to one of the brown leads (SWI) from the Ignition module. Connect the remaining brown lead from the ignition module to the burner switch. Ensure that both leads, the brown lead from the module and the wire lead from the pressure switch are on the same side of the switch, see fig #5.
- 7) Connect the on/off switch wire lead, provided with the kit, to the other side of the burner switch. This side controls the AC current for the power vent blower.
- 8) Remove two screws holding the upper control panel in place and carefully remove panel and set aside. Remove the electrical receptacle cover box, held in place with two screws, to access the AC wiring from the blower, see fig #6.
- 9) Route the on/off switch wire through the ½" hole in the cover. Earlier units did not have an access hole in the cover and must be replaced with one supplied in the kit.
- 10) Finish all other wiring as necessary and replace receptacle cover box.
- 11) Attach the silicone tube from the pressure tapping on the vent adaptor to the "low" side of the pressure switch and secure using hose clamp provided, see fig #7.
- 12) Reattach both upper and lower control panels with screws previously removed.

Fig. #4

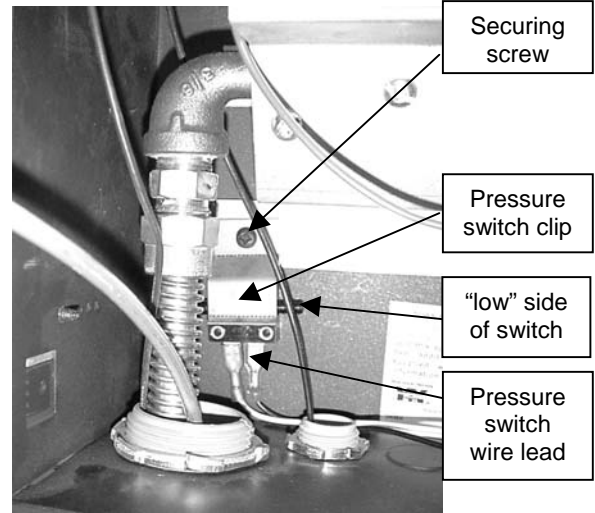
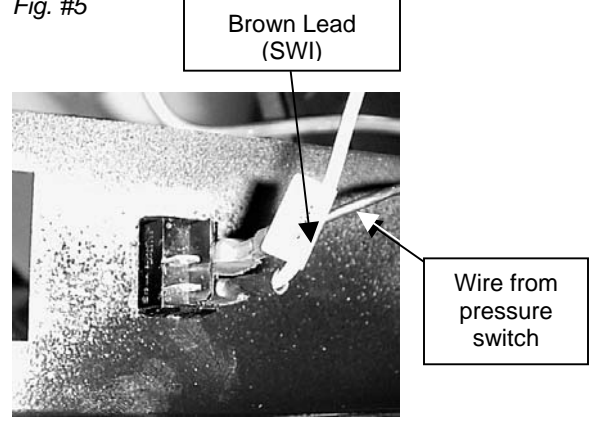

Fig. #5



WALL SWITCH INSTALLATION

If a wall switch is required the switch must be placed in the AC power supply for the control box. When using the wall switch ensure that the burner switch is in the "on" position. With the switch in this position, operating the wall switch to turn the fan on and off will also turn the fireplace on and off.

WALL THERMOSTAT INSTALLATION (Canada only)

Installation is the same as for the wall switch. Please note a 110v thermostat must be used.

Fig. #6

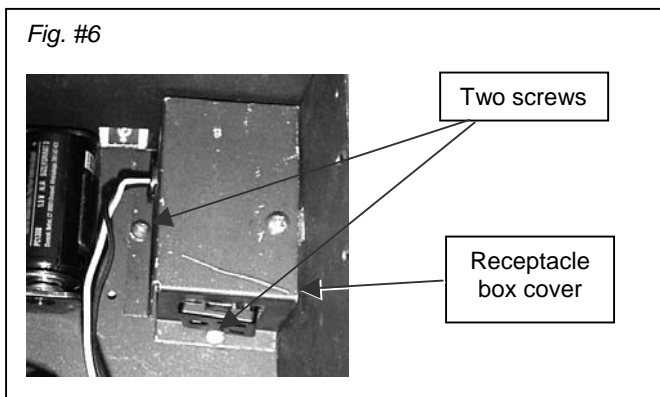
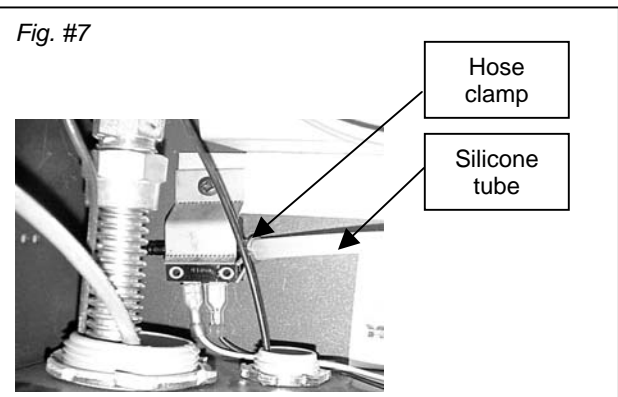
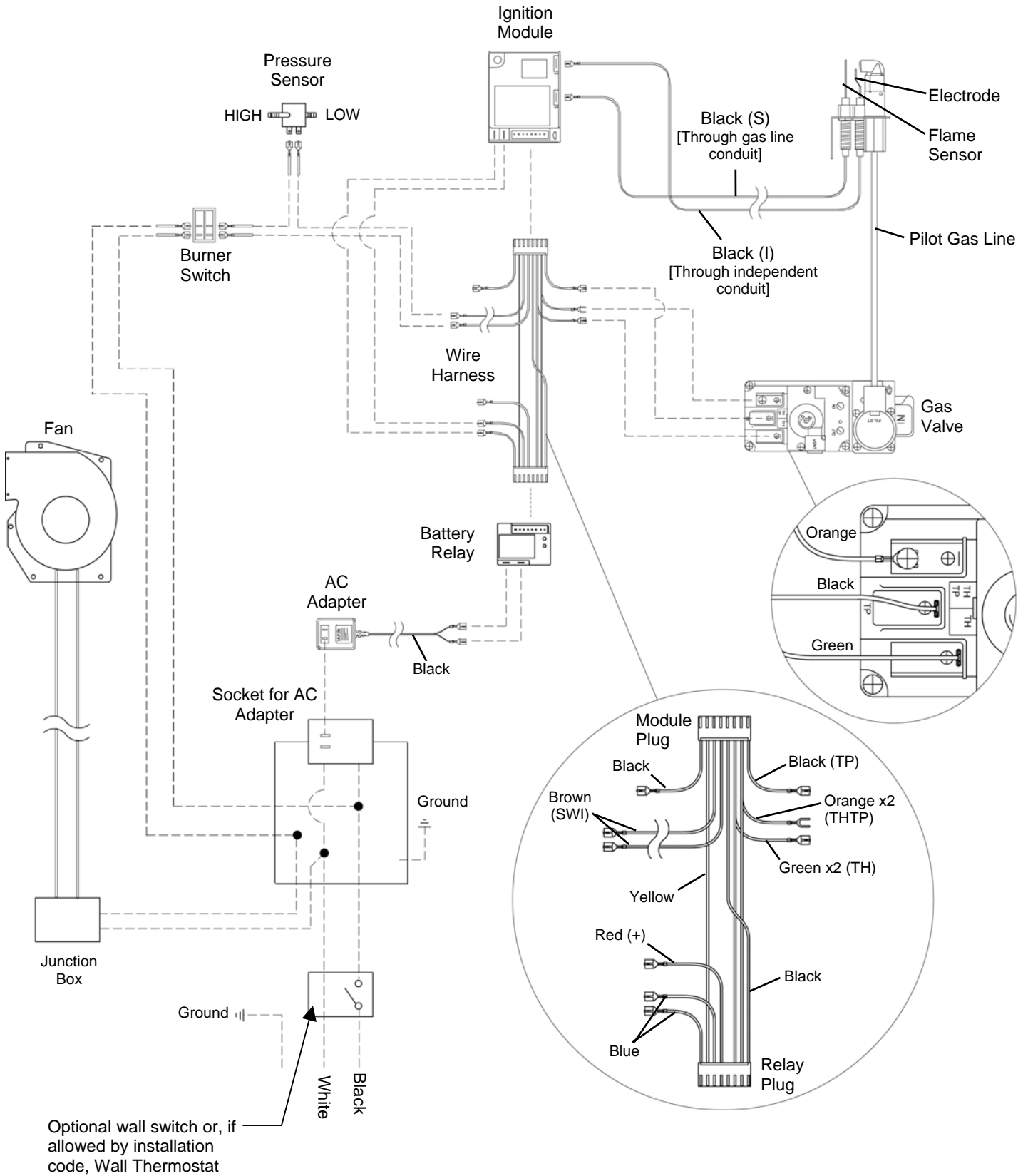

Fig. #7



WIRING DIAGRAM



REPLACEMENT PARTS

Item	Part No.	Description	Qty	Item	Part No.	Description	Qty
1	5024.61	Blower, power vent kit	1	15	8063	Intake cover	1
2	5041.12	SCREW, 8x1/2 PH SMS	14	16	8064.01	Fan outlet collar	1
3	5043.64	Spacer, SP100 3/4	4	17	TCVT.8051	Vent collar assembly	1
4	5043.064	Lock washer	5	18	TCVT.80511	Vent exhaust assembly	1
5	5043.5	Type a plain washer	4	19	TCVT.506251	Blower wiring	1
6	5046.3	Screw, 8-32x1.75 PH	4	20	TCVT.506271	Pressure switch wiring	1
7	5049.53	Nut, 8-32 HEX PLTD	4	21	TCVT.507156	On/Off switch wiring	1
8	5049.67	Bolt, 1/4-20x1/2 HEX PLTD	5	22	9072.7	Pressure switch clip	1
9	5068.8065	Blower gasket	1	23	5027.1	Pressure switch	1
10	5072	Wire bushing, B625-500	2	24	5096.813	Venting adapter	1
11	8053.1	Side cover, right	1	25	8065	Rain shield	2
12	8053.2	Side cover, left	1	26	5004.085	Silicone Tube	1
13	8054	Exhaust vent cover	1		5071.5	On/Off Switch, (not shown)	1
14	8055	Exhaust deflector	1		9079.01	Receptacle Box (not shown)	1
					5093.01	Hose clamp (not shown)	2

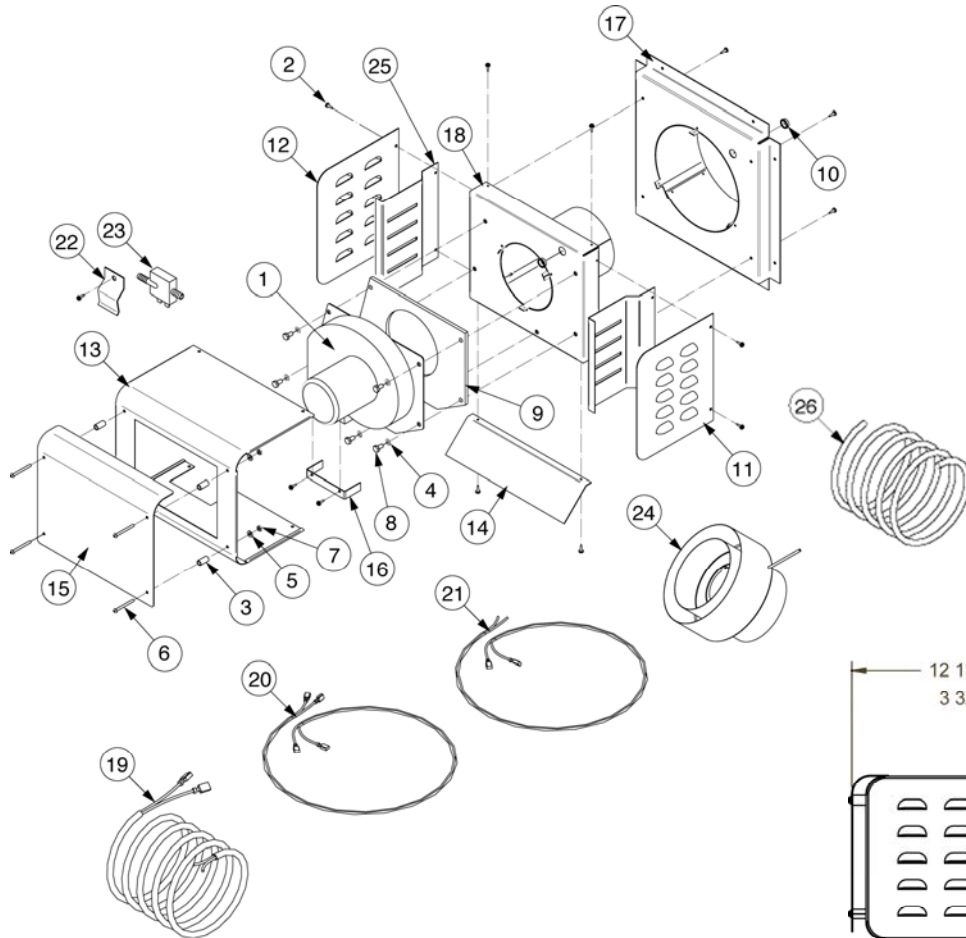

**POWER VENT TERMINAL
DIMENSIONS**

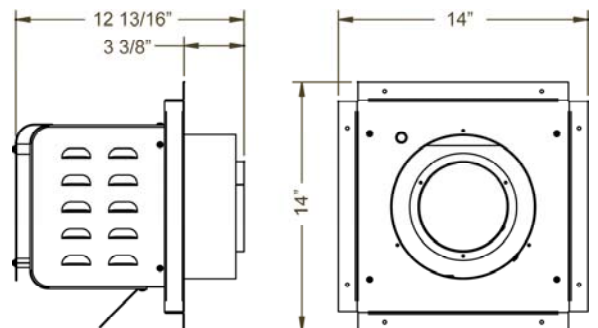

VENTING COMPONENTS

Simpson Duravent Components

Number	Description
1208	6" Pipe Length
1207	9" Pipe Length
1206	12" Pipe Length
1204	24" Pipe Length
1203	36" Pipe Length
1202	48" Pipe Length
1211	11" to 14-5/8" Pipe, Adjustable,
1217	17" to 24" Pipe, Adjustable,
1245	45° Elbow
1290	90° Elbow
1240	Round Ceiling Support /Wall Thimble Cover
1241	Cathedral Ceiling Support Box
1242	Wall Firestop
1247	Wall Thimble
1263	Ceiling Firestop
1288	Wall Strap

Secure Vent Components

CAT. NO.	Description
SV5L6	Length 6"
SV5L12	Length 12"
SV5L24	Length 24"
SV5L36	Length 36"
SV5L48	Length 48"
SV5LA	Adjustable length (adjustable 6")
SV5LA12	Adjustable length (adjustable 12")
SV5LA24	Adjustable length (adjustable 24")
SV5E45	Swivel 45° elbow
SV5E90	Swivel 90° elbow
SV5CSB	Adjustable decorative square cathedral support
SV5AC	Collar for decorative square cathedral support
SV5SU	Universal support
SV5SD	Floor support
SV5BM	Wall band
SV5RSA	Attic radiation shield
SV5RSM	Wall radiation shield
SV5BF	Firestop



TOWN & COUNTRY
FIREPLACES™

2975 Allenby Road, Duncan, B.C. V9L 6V8

Phone: 1-888 223 0088

Web site: <http://www.townandcountryfireplaces.net>

Printed in Canada