

**IMPORTANT:
THESE INSTRUCTIONS ARE TO REMAIN
WITH THE HOMEOWNER**

These instructions are supplementary to the Installation and Operating Instructions supplied with the fireplace and should be kept together. Refer to the Installation and Operating Instructions for proper gas supply, safety requirements and operating instructions.



**TOWN & COUNTRY
FIREPLACES™**

TC36 TRANQUILITY BURNER KIT INSTRUCTIONS



**PART# TC36.NG04.C
For TC36 Series C**



Contents of Package

- 1 BURNER ASSEMBLY
- 1 PANEL, BASE
- 1 PEBBLE ASSEMBLY
- 2.2 LBS. SAND
- 1 COVER RHS
- 1 COVER LHS
- 1 BAG TAPERED PLUGS (NOT SHOWN)



Tranquility Burner Installation

If converting to propane see conversion instructions on page #6 before proceeding.

NOTE: Plug the 4 vacant holes in the bottom of the firebox with 1/2" screws, as they are not required to attach this style of burner.

1. Bend flex lines into the approximate shape. (Fig #1)
2. Place covers under the burner tray. (Fig #2a & 2b)

NOTE: Shutter must be fully closed for Natural gas, fully open for Propane.

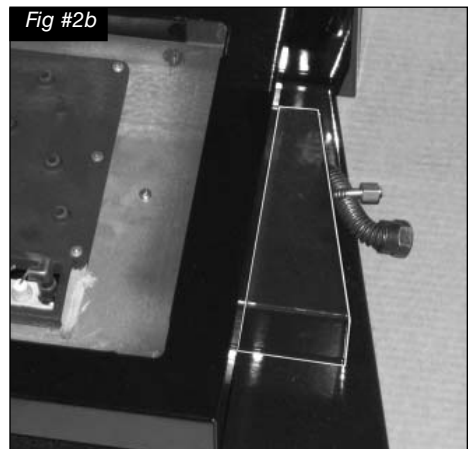
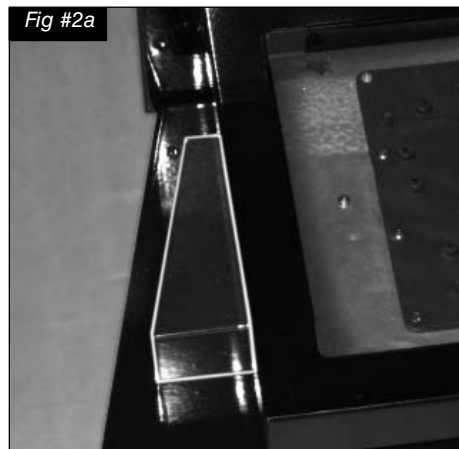
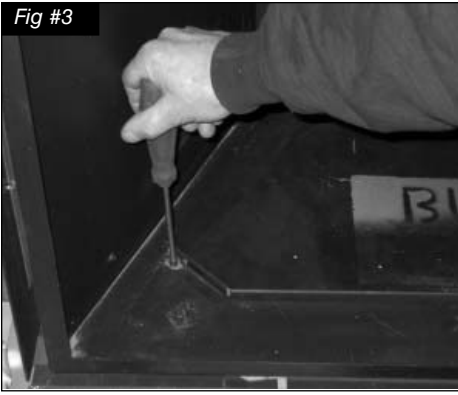

Fig #3



3. Remove floor shield (2 screws) and discard. Replace screws to plug vacant holes.

Fig #4



4. Place burner assembly partially into unit. (Fig #4)

Fig #5

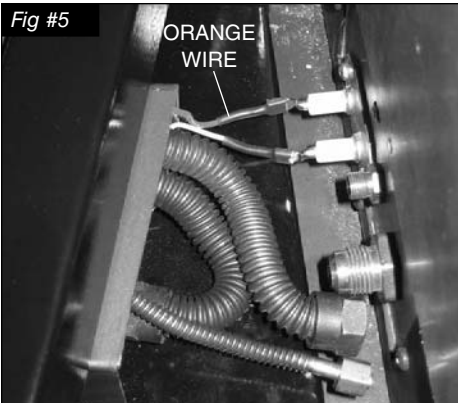

5. Connect spark electrode wire (ORANGE) to the rear electrical bulk head fitting. Connect the flame sensor wire to the front electrical bulk head fitting. (Fig. #5)

Fig #6



6. Attach fuel flex lines to bulkhead fittings. (Fig. #6 & 7)

CAUTION:
Ensure that all connections are gas tight.

Fig

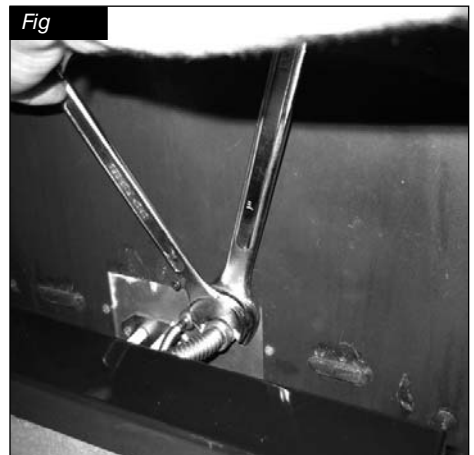



7. Remove panel retainer clips from upper heat shield. Install left porcelain panel tilting in from front corner then install upper rear porcelain panel. (Fig #8)



8. Install right porcelain panel tilting in from front corner lifting rear panel to clear tabs. (Fig #9)

Re-install panel retainers.

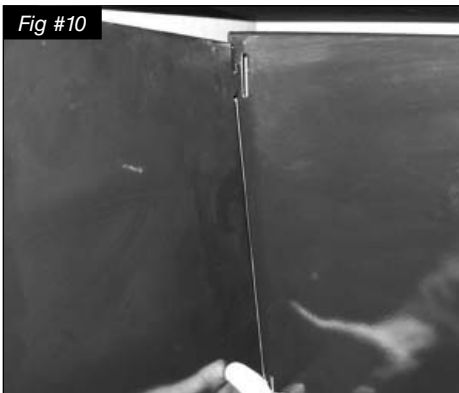

9. Line up top and bottom slots on rear panel with top and bottom tabs on both side panels. (Fig #10)



10. Remove 2 side screws from lower position of air channel.



11. Install lower rear panel using previously removed screws. Slide burner assembly into the firebox. (Fig #12)



12. Slide covers out and attach to base with one screw each. (Fig #13)

Fig #14

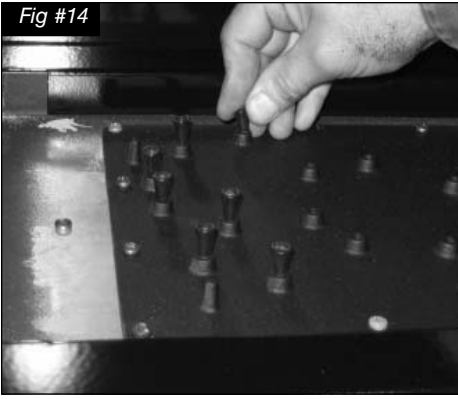

13. Insert tapered plugs into raised burner ports to prevent sand from entering ports. (Fig #14)

Fig #15



14. Place sand in tray. Brush sand smooth and level to just below top of raised burner ports. Gently blow excess sand from around ports. (Fig #15)

14. Remove tapered plugs from ports.

Fig #16



15. Remove pebble assembly from packaging by placing hand on top and tipping upside down. Gently place pebble assembly onto sand base using pins to locate position. (Fig #16)

NOTE:

**Lift pebble assembly from bottom.
Do not lift by top rocks.
Hollowed out rock must cover the
pilot.**

Fig #17



17. Install glass door. Unit is ready for lighting.

Propane Conversion

WARNING

This conversion kit shall be installed by a qualified service agency in accordance with the manufacturer's instructions and all applicable codes and requirements of the authority having jurisdiction.

If the information in these instructions is not followed exactly, a fire, explosion or production of carbon monoxide may result causing property damage, personal injury or loss of life.

The qualified service agency is responsible for the proper installation of this kit.

The installation is not proper and complete until the operation of the converted appliance is checked as specified in the manufacturer's instructions supplied with the kit.

If the unit is to be used on propane convert as follows using the components supplied with this burner:

CAUTION

The gas supply and electrical power shall be shut off before proceeding with the conversion.

Note:

Factory supplied components must be used to ensure correct input. After conversion confirm proper manifold pressure.

The burner assembly must be removed from the unit if previously installed.

1. Remove the 2 front screws holding the burner tray in place. (Fig. #18)
2. Gently lift up the burner tray while sliding to the left to disengage the burner tube from the orifice. Then tip back to expose the orifice.
3. Using a 1/2" wrench, undo the natural gas burner orifice, (marked #30). Apply a small amount of pipe joint compound to the threads of the propane burner orifice (marked #45) to ensure a good seal, before screwing it into the fitting. Loosen the primary air shutter screw, open shutter fully and re-tighten. (Fig. #19)
4. Remove the pilot assembly using a stubby screwdriver to remove the 2 screws holding it in place. (Fig. #20)

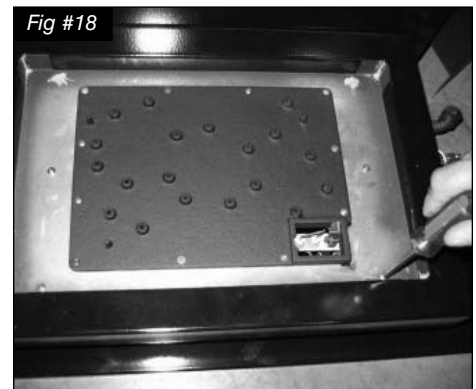
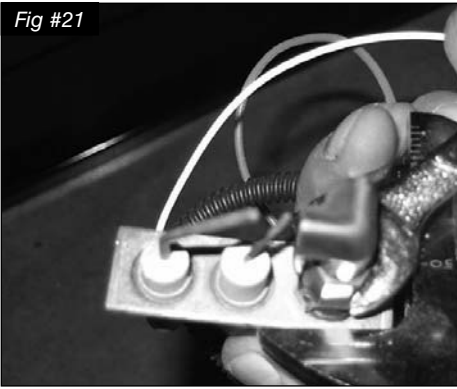
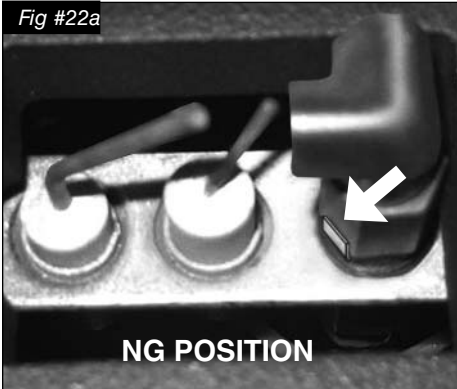

Fig #21



5. With a 7/16" wrench loosen the pilot head on the pilot assembly using a wrench to hold the bracket steady. (Fig. #21)

Fig #22a



6. Slide the pilot adjustment band over and ensure that the hole in the orifice band is showing.

◀ Fig. #22a shows NG position

Fig. #22b shows LP position). ▶

Re-attach the pilot assembly.

Fig #22b

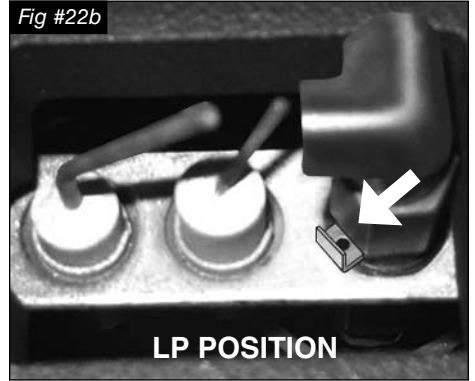

7. Remove the access panel, 10 screws, and set aside.

Fig #23



8. Remove the minimum rate screw located in the valve. (Fig. #23)

The minimum rate screw is sealed with an o-ring. Use a thin bladed screwdriver to back the screw out past the limit of the threading. At this point a groove on the screw body will be visible just above the valve body. Insert a thin tool (knife blade or fine screwdriver blade) into the groove and gently pry the screw up. It helps to rotate the screw while lifting on it.

Fig #24

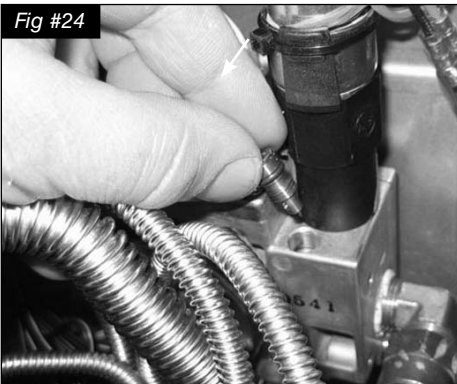

9. Replace the minimum rate screw with the one provided in the propane conversion kit supplied with this fireplace. Ensure that the screw is fully seated. (Fig. #24)

10. Pull off the rubber cap from the top of the pressure regulator.
(Fig. #25)



11. Press down on the center post and rotate 90°. The center post should stay down. (Fig. #26). Replace the rubber cap.
12. Fill in the date and the name of the person who performed the conversion in the white area on the conversion label. Peel off the protective backing and apply the conversion label directly over the gas specifications on the rating label.

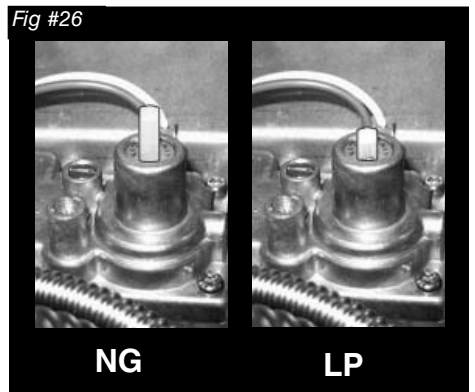

13. Re-attach the access panel to the side of the firebox with the screws previously removed. (Fig. #27)

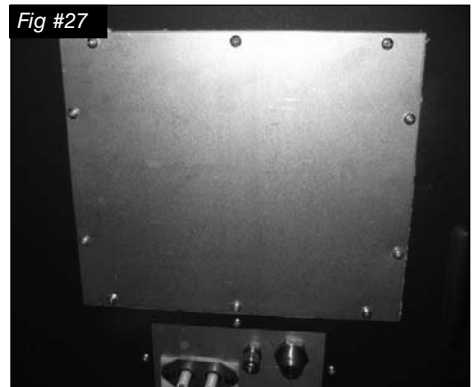

Gas Pressure Check

Note: To test the gas pressure, turn off the gas supply before removing the plug from the supply pressure test port or manifold pressure test port.

Verify gas pressures with the fireplace lit and on the highest setting.



1. Remove the plug from the pressure test port using a 7/16" socket and extension. The plug is located between the right side lintel and firebox side. (Fig. #28)

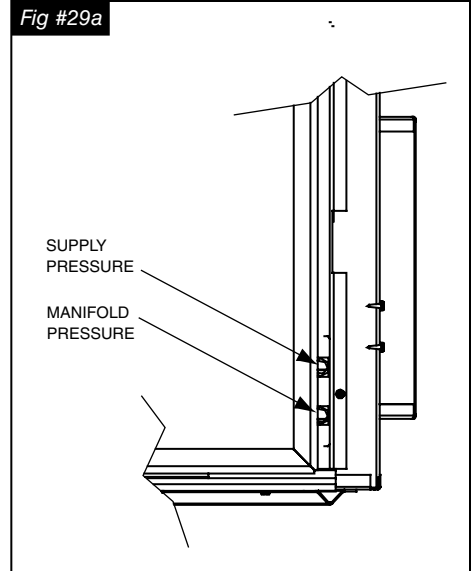

2. Thread the extension test fitting into the open port. (Fig. #29)
3. Attach a pressure gauge onto the fitting.
4. When testing is complete shut off the gas, remove the fitting and replace the plug. Thread sealant will be required to ensure a gas tight connection.

Correct gas pressure requirement:

Supply Pressure	Natural Gas	Propane
Min. Pressure (For purpose of input adjustment)	5.0" WC	12.5" WC
Max. Pressure	13.9" WC	13.9" WC
Manifold Pressure		
Maximum	3.8" WC	11" WC
Minimum	2.1" WC	5.5" WC

Burner Flame Adjustment

The air shutter on the burner tube controls the primary combustion air. It is set to the closed position at the factory for natural gas fuel. Some adjustment may be necessary to obtain desired flame and to eliminate carbon deposits. Evaluate flame appearance after the fireplace has reached operating temperature. See Fig. #30 for proper flame pattern.

Open primary air if the window glass and firebox have carbon accumulation and/or the flames are long, dark and stringy. The shutter may also be opened to lessen the flame height.

Fig #30



NOTE:
Proper air shutter setting is required.

The flame should be just orange and “lazy”. It should NEVER be set to create sooting on internal parts and window glass.

Replacement Parts

(WHEN ORDERING, INCLUDE PART NUMBER WITH DESCRIPTION)

ITEM.....	DESCRIPTION.....	PART NO.
#1.....	TRANQUILITY BURNER KIT	TC36.NG04
#2.....	PEBBLE ASSEMBLY	TC36.9499
#3.....	MAIN SUPPLY TUBE.....	5019.223
#4.....	PILOT TUBE	5019.225

ITEM.....	DESCRIPTION.....	PART NO.
#5.....	PILOT ASSEMBLY, CONVERTIBLE ..	5005.025
#6.....	ORIFICE, NATURAL GAS (#30).....	5022.13
* #7.....	PROPANE CONVERSION KIT	TC36.LPCE01
* #8.....	SAND	TC36.SAND22

★ NOT SHOWN

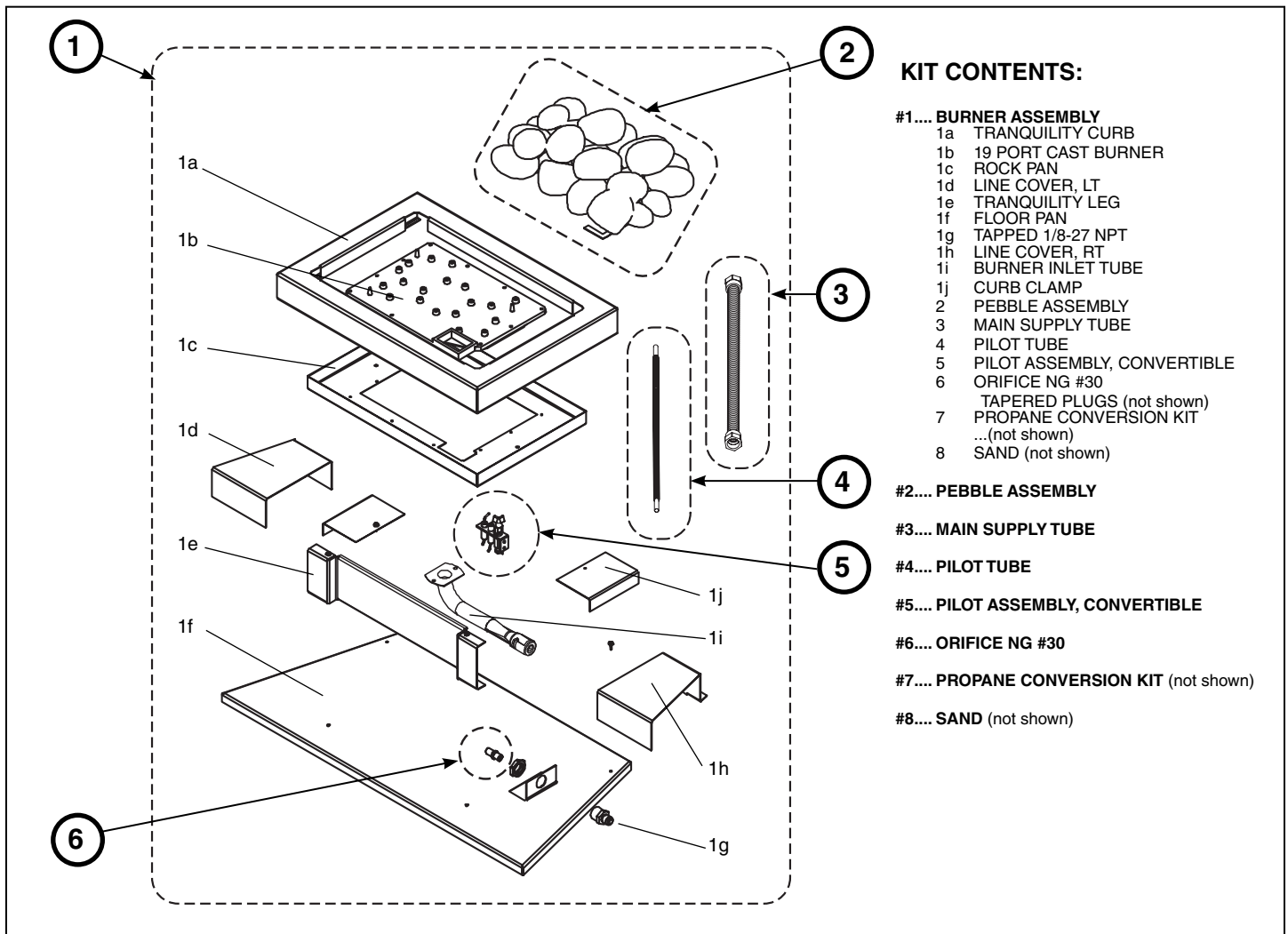



TOWN & COUNTRY
FIREPLACES™

Technical support: 1-877-715-2664
Web site: www.townandcountryfireplaces.net
2975 Allenby Rd., Duncan, BC V9L 6V8