

**IMPORTANT:  
THESE INSTRUCTIONS ARE TO REMAIN  
WITH THE HOMEOWNER**

These instructions are supplementary to the Installation and Operating Instructions supplied with the fireplace and should be kept together. Refer to the Installation and Operating Instructions for proper gas supply, safety requirements and operating instructions.



**TOWN & COUNTRY  
FIREPLACES™**

## **TC36 SEE-THRU CHALET BURNER KIT INSTRUCTIONS**



**PART#  
TC36.NGST01.C  
FOR TC36 SEE-THRU**



## Package Contents

- BURNER/GRATE ASSEMBLY
- 11 PCS LOG SET
- PILOT ASSEMBLY
- GAS FLEX LINE
- 2 EMBER MATERIAL
- HARDWARE PACKAGE



## Burner/Grate Installation

In these instructions the right and left sides of the fireplace are referenced during the installation process. The right side of the unit has the control access cover in it.

1. Attach the burner/grate assembly to the floor of the firebox with four screws.(Fig. # 1)

Fig. # 1

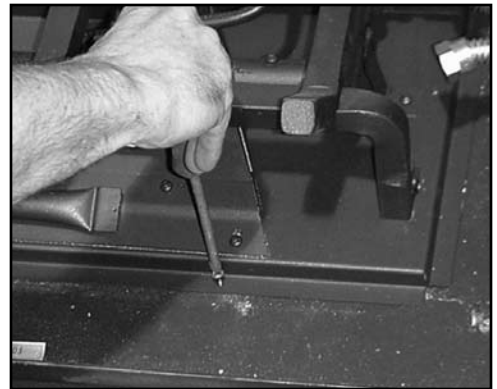

2. Connect the flex hoses from the pilot and the main burner supply to the bulkhead fittings on the firebox. (Fig. # 2)

Fig. # 2

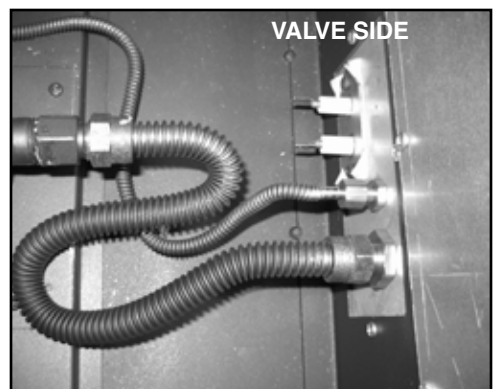

3. Connect the electrical connections from the pilot assembly to the connections in the firebox side. Ensure that the orange wire from the spark electrode is connected to the rear of the two connectors (marked with colored dot) in the bulkhead, as viewed with control on right side. (Fig. # 3)

Fig. # 3

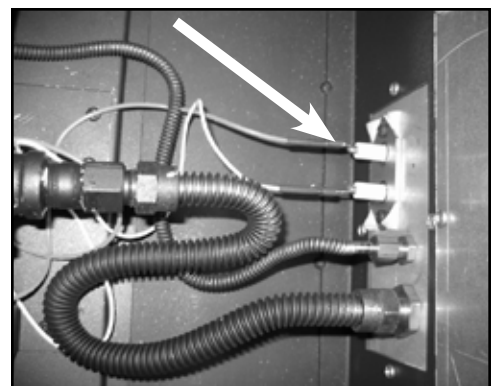

# Propane Conversion

If the unit is to be used on propane, convert as follows using the components supplied with this fireplace:

## WARNING

This conversion kit shall be installed by a qualified service agency in accordance with the manufacturer's instructions and all applicable codes and requirements of the authority having jurisdiction. If the information in these instructions is not followed exactly, a fire, explosion or production of carbon monoxide may result causing property damage, personal injury or loss of life. The qualified service agency is responsible for the proper installation of this kit. The installation is not proper and complete until the operation of the converted appliance is checked as specified in the manufacturer's instructions supplied with the kit.

## CAUTION

The gas supply and electrical power shall be shut off before proceeding with the conversion.

Note: Factory supplied components must be used to ensure correct input. After conversion confirm proper manifold pressure.

1. Ensure the burner, pilot and gas supply are turned off, and the appliance has cooled.
2. Note log positions and carefully remove them (if installed).
3. Remove the log grate.
4. (Continued on next page)

- Remove the 2 front screws holding the burner tray in place and slide tray side-ways to access burner orifice. (Fig. #4)

Fig. # 4

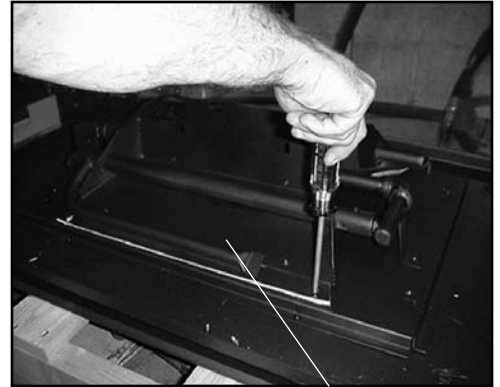

Burner Tray Assembly

- Using a 1/2" wrench, undo the natural gas burner orifice, (marked #32). (Fig. #5)
- Apply a small amount of pipe joint compound to the threads of the propane burner orifice (marked 1.8 mm) to ensure a good seal, before screwing it into the fitting.
- Repeat procedures 4, 5 & 6 for the other side.
- Reposition the manifold assembly and fasten in place with screws previously removed.
- Open primary air shutters fully.
- Replace the log grate.
- With a 7/16" wrench loosen the pilot head on the pilot assembly (Fig. #6)
- Slide the pilot adjustment band over and ensure that the hole in the orifice band is showing. (Fig. #7 indicates NG position, Fig. #8 indicates LP position)

Fig. # 5



Burner Orifice

Fig. # 6



Fig. # 7

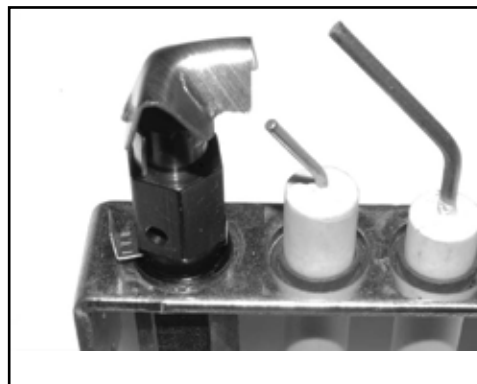
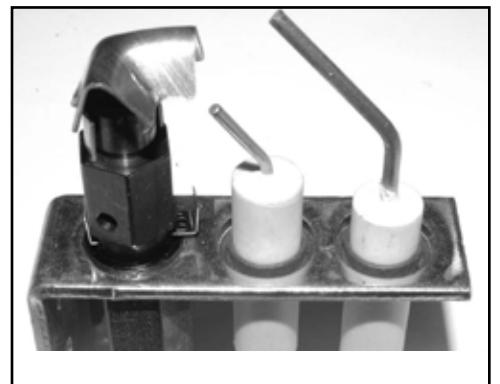

Fig. # 8



13. Remove access panel, 10 screws, and set aside (Fig. #13)

14. Remove the minimum rate screw located in the valve. (Fig. #9)

#### Removing the Minimum Rate Screw

The minimum rate screw is sealed with an o-ring near the bottom of the screw. Use a thin bladed screwdriver to back the screw out to the limit of the threading. At this point, a groove on the screw body will be visible just above the valve body. Insert a thin tool (knife blade or fine screwdriver blade) into the groove and gently pry the screw up. It helps to rotate the screw while lifting on it.

Fig. # 9

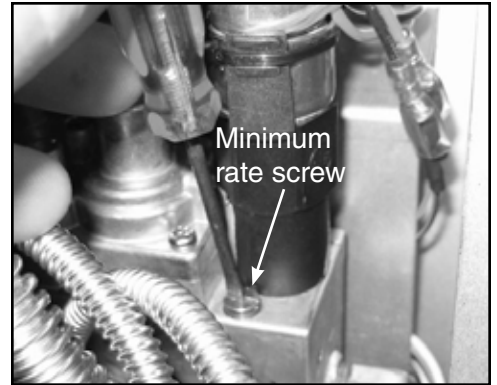
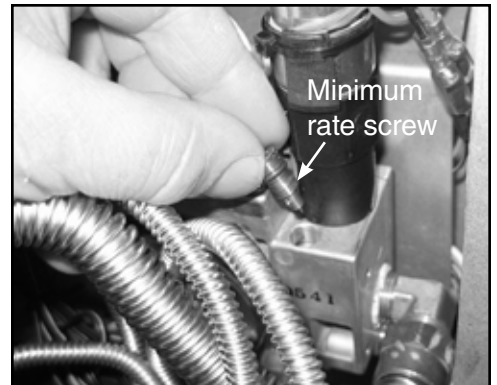

Fig. # 10



15. Replace the minimum rate screw with the one provided in the propane conversion kit supplied with this fireplace. Ensure that the screw is fully installed. (Fig. #10)

Fig. # 11



16. Pull off the rubber cap from the top of the pressure regulator. (Fig. #11)

Fig. # 12

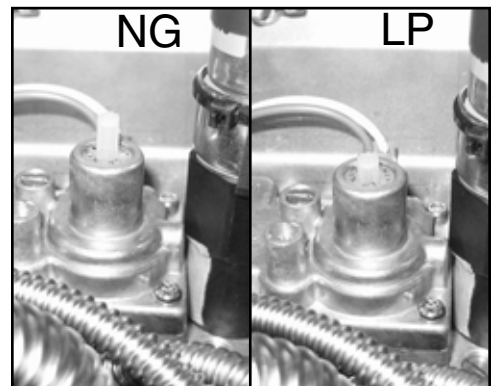

17. Press down on the center post and rotate 90°. The center post should stay down. (Fig. #12). Replace the rubber cap.

18. (Continued on next page)

18. Fill in the date and the name of the person who performed the conversion in the white area on the conversion label. Peel off the protective backing and apply the conversion label directly over the gas specifications on the rating label.
19. Attach the access panel to the side of the firebox with the previously removed screws. (Fig. #13)

**Note: Gasket must be installed with access panel.**

Fig. # 13

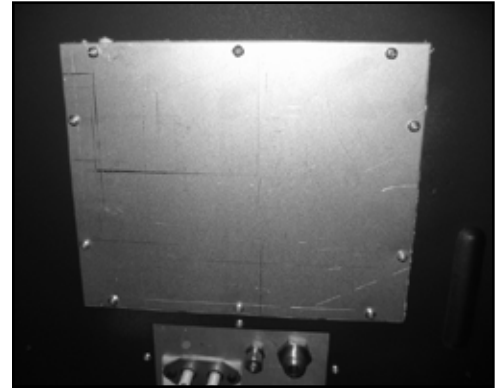

## Gas Pressure Check

**Note:** To test the gas pressure, turn off the gas supply before removing the blanking plug from the supply pressure test port or manifold pressure test port. Verify gas pressures with the fireplace lit and on the highest setting.

1. Remove the blanking plug from the pressure test port. The plug is located between the right side lintel and firebox side. (Fig. # 14)

Fig. # 14

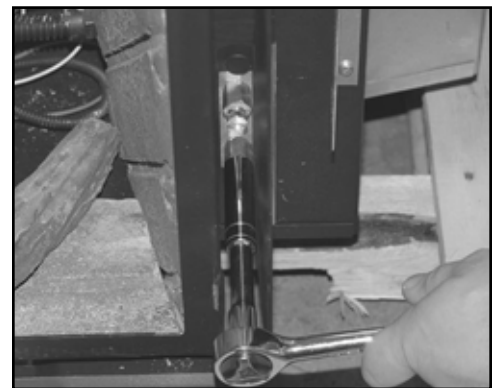

### CORRECT GAS PRESSURE REQUIREMENT:

Supply Pressure	Natural Gas	Propane
<small>(For purpose of input adjustment)</small>		
Minimum	5.0" wc	12.5" wc
Maximum	13.9" wc	13.9" wc
<b>Manifold Pressure</b>		
Maximum	3.8" wc	11.0" wc
Minimum	2.1" wc	5.5" wc

Fig. # 15



2. Thread the extension test fitting into the open test port. (Fig. # 15)
3. Attach a pressure gauge onto the fitting.
4. When testing is complete, shut off the gas, remove the fitting and replace the blanking plug. Thread sealant will be required to ensure a gas tight connection.

## Ember Material

Two large bags of ember material are shipped with the fireplace and need to be installed to ensure optimum performance and flame appearance.

Pull apart the material into ember size pieces (approximately 1" squares) and gently place them into the burner pan. Do not compress, leave it loose for best performance. Fill the burner pan level with the top of the pan at rear, and gradually slope forward down to the firebox floor at the front, covering both burner tubes. Place remaining ember material outside of the burner pan as desired to cover-up gas lines and brackets.

Note: Ember material placement and amount will affect flame appearance. More ember material results in lower flame height. Add or remove as needed until desired flame affect. Reduce the amount used on Propane models, as too much will create soot.



**GLOWING EMBERS**

## Log Set Assembly

The logs are packaged in a foam pack inside the box and are fragile, and should be handled with care. Unpack and inspect log set. There should be a total of 11 logs. Gas plumbing and vent connections should be completed before proceeding. Position the logs as indicated by the following pictures.

### Step 1

#### CENTER LOG PLACEMENT

1. Align the center log with the pins located at the center of the grate

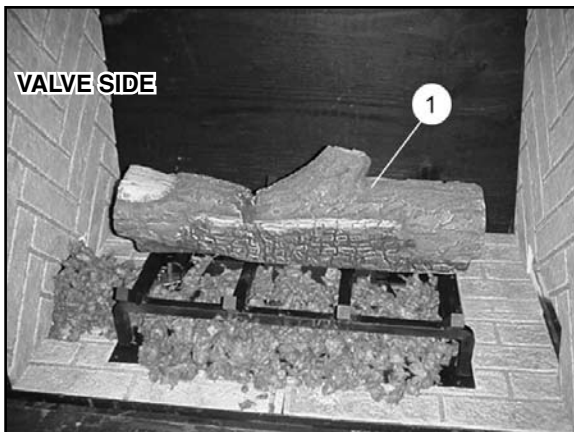

### Step 2

#### RIGHT LOG PLACEMENT

2. Place right log as pictured.

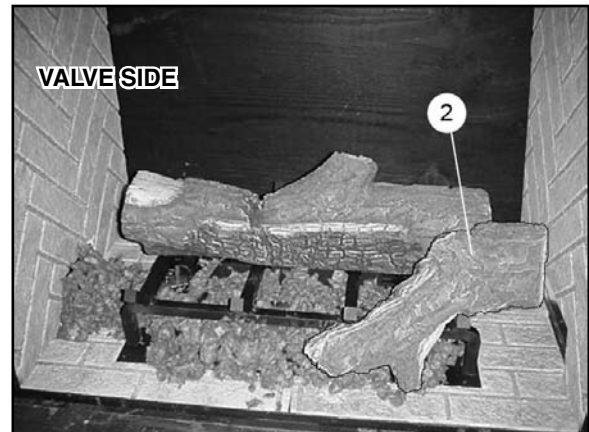

## Step 3

### LEFT LOG PLACEMENT

3. Install the left log onto the grate straddling the grate as shown.



## Step 4

### LEFT END LOG PLACEMENT

4. Install the left end log on the floor near the left leg of the grate as shown.



## Step 5

### RIGHT END LOG PLACEMENT

5. Place the right end log near the right leg of the grate as shown.



## Step 6

### CENTER FLOOR LOG PLACEMENT

6. Place the center floor log over the joint in the floor panels as shown.

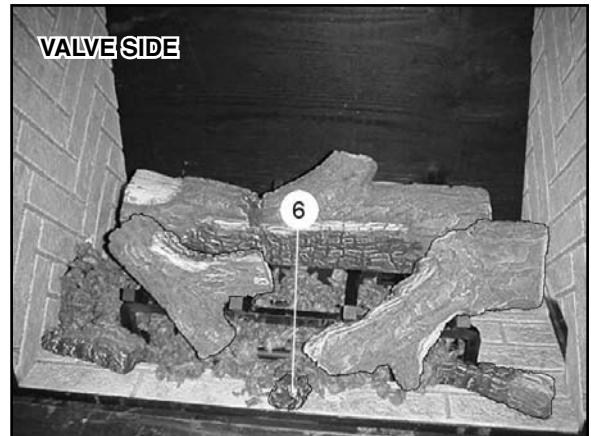

### LOG PLACEMENT, VIEW FROM OTHER SIDE



Repeat the procedure for the remaining logs on the other side of the unit. See Steps 1 – 11

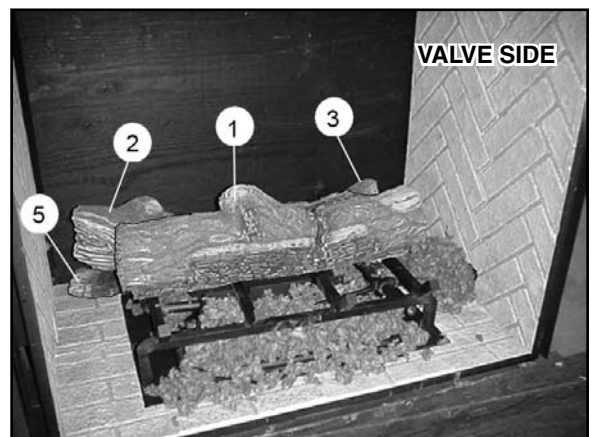

## Step 7

### RIGHT LOG PLACEMENT

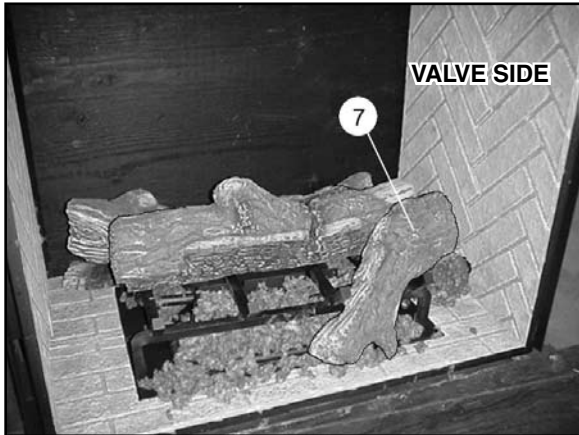

## Step 8

### LEFT LOG PLACEMENT

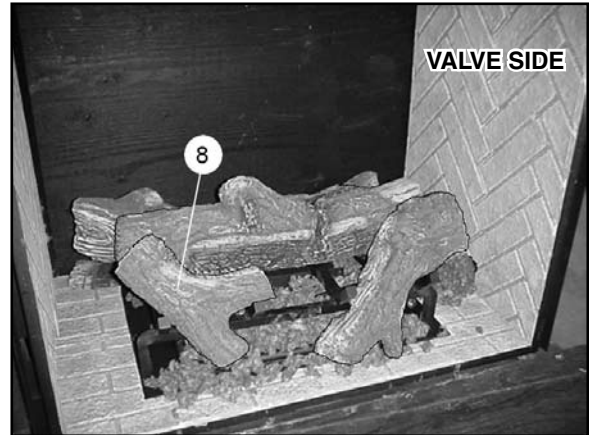

## Step 9

### LEFT END LOG PLACEMENT

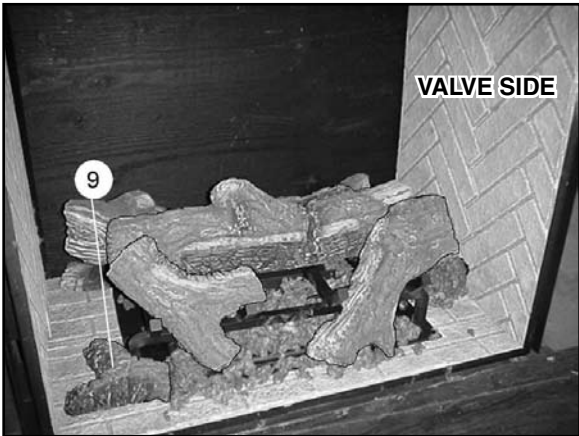

## Step 10

### RIGHT END LEFT LOG PLACEMENT

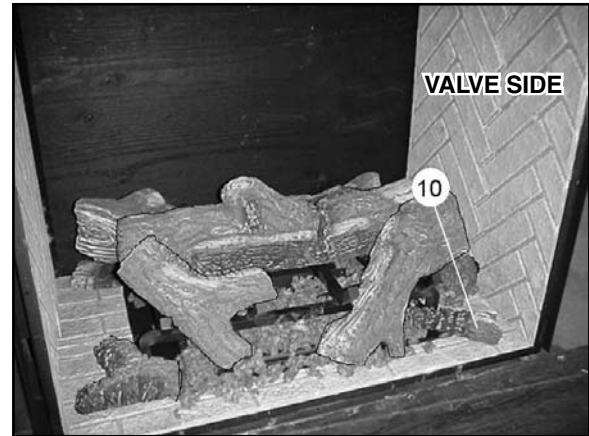

## Step 11

### CENTER FLOOR LOG PLACEMENT

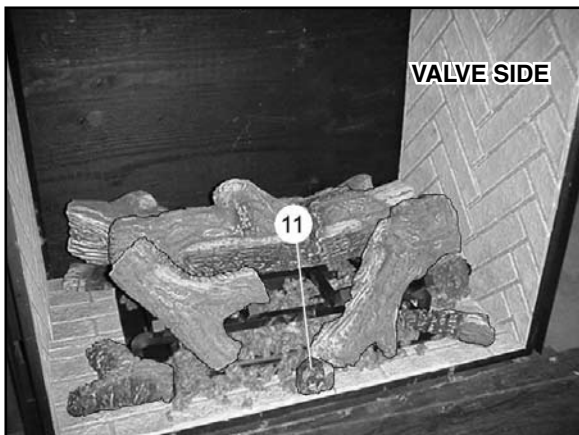

**Note:** Improper placement of logs will create soot on internal parts and glass.

# Burner Flame Adjustment

The air shutter on the burner tube controls the primary combustion air to the gas burner and is pre-set closed at the factory for natural gas fuel. Some adjustment may be necessary to obtain desired flame and to eliminate carbon deposits. Evaluate flame appearance after the fireplace has reached operating temperature. See Fig. #23 for proper flame pattern.

Open primary air if the logs, glass, and firebox have carbon accumulation and/or the flames are long, dark and stringy. The shutter may also be opened to enhance the Ember Material glow and lessen the flame height.

**Caution: Burner area may be hot!**

Turn off the fireplace and allow the unit to cool before proceeding.

**To Adjust:** (See Fig. # 22)

1. Open and remove window frame and set aside. See "Window Frame Removal" section found in the Installation and Operating Instructions manual.
2. Remove the log set and set aside.
3. Loosen the screw in the Primary Air Shutter.
4. Rotate the shutter to increase or decrease the amount of primary air.

**Caution: Proper air shutter setting is a must.**

The flame should be just orange and "lazy." It should NEVER be set to create sooting on internal parts and glass.

PRIMARY AIR SHUTTERS

Fig. # 22

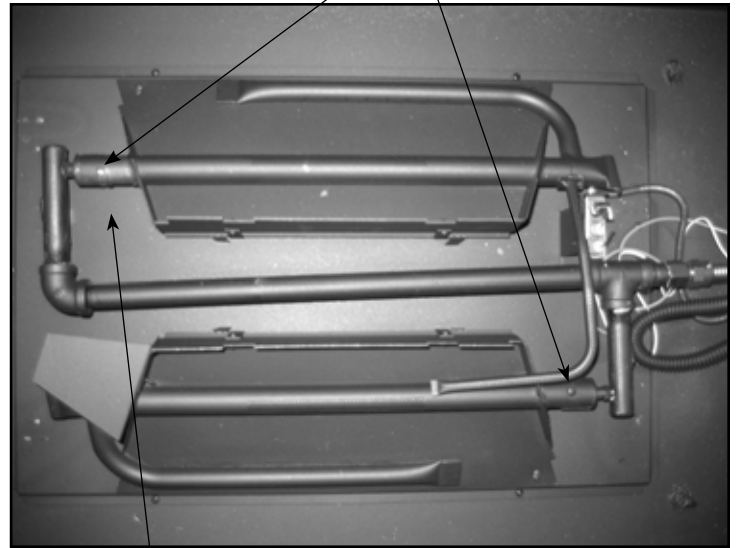

\*SIDE BRACKET HAS BEEN REMOVED TO SHOW

Fig. # 23



HERRINGBONE PANEL SET SHOWN

# Replacement Parts

ITEM.....DESCRIPTION.....PART NO.

1.....	LOG GRATE.....	TC36.9381WELD
2.....	BURNER TRAY SUPPORT SHIELD.....	9369.001
3.....	BURNER TRAY, FR.....	TC36.9370FWELD
4.....	SIDE BRACKET, FR.....	9370.6
* 5.....	MANIFOLD ASM.....	TC36.93711
6.....	SIDE BRACKET, RR.....	9370.51
7.....	BURNER TRAY, RR.....	TC36.9370RWELD
8.....	LIGHTER TUBE.....	TC36.5011841WLD
9.....	MANIFOLD FITTING.....	5019.221
10.....	ORIFICE, NG.....	5021.332.A
	ORIFICE, LP.....	5022.85
11.....	PILOT BRACKET.....	9372.5
* 12.....	FIREBOX HEAT SHIELD.....	9389.02
13.....	HEAT SHIELD GASKET.....	9389.5

ITEM..... DESCRIPTION .....PART NO.

14...	1/4" FLEX COMPRESSION.....	5019.225
15...	1/2" FLEX FLARE CONNECTION.....	5019.223
16...	PILOT ASSEMBLY.....	TCRP.5005025
	LOG SET, COMPLETE.....	5098.74613
	..... CENTER, #1 (shown in fig.#5).....	5098.746121
	..... MIDDLE RIGHT, #2 (shown in fig.#6).....	5098.746123
	..... MIDDLE LEFT, #3 (shown in fig.#6).....	5098.746122
	..... FRONT LEFT, #4 (shown in fig.#6).....	5098.746124
	..... FRONT RIGHT, #5 (shown in fig.#7).....	5098.746126
	..... FRONT CENTRE, #6 (shown in fig.#7).....	5098.746125

\* NOT SOLD SEPARATELY

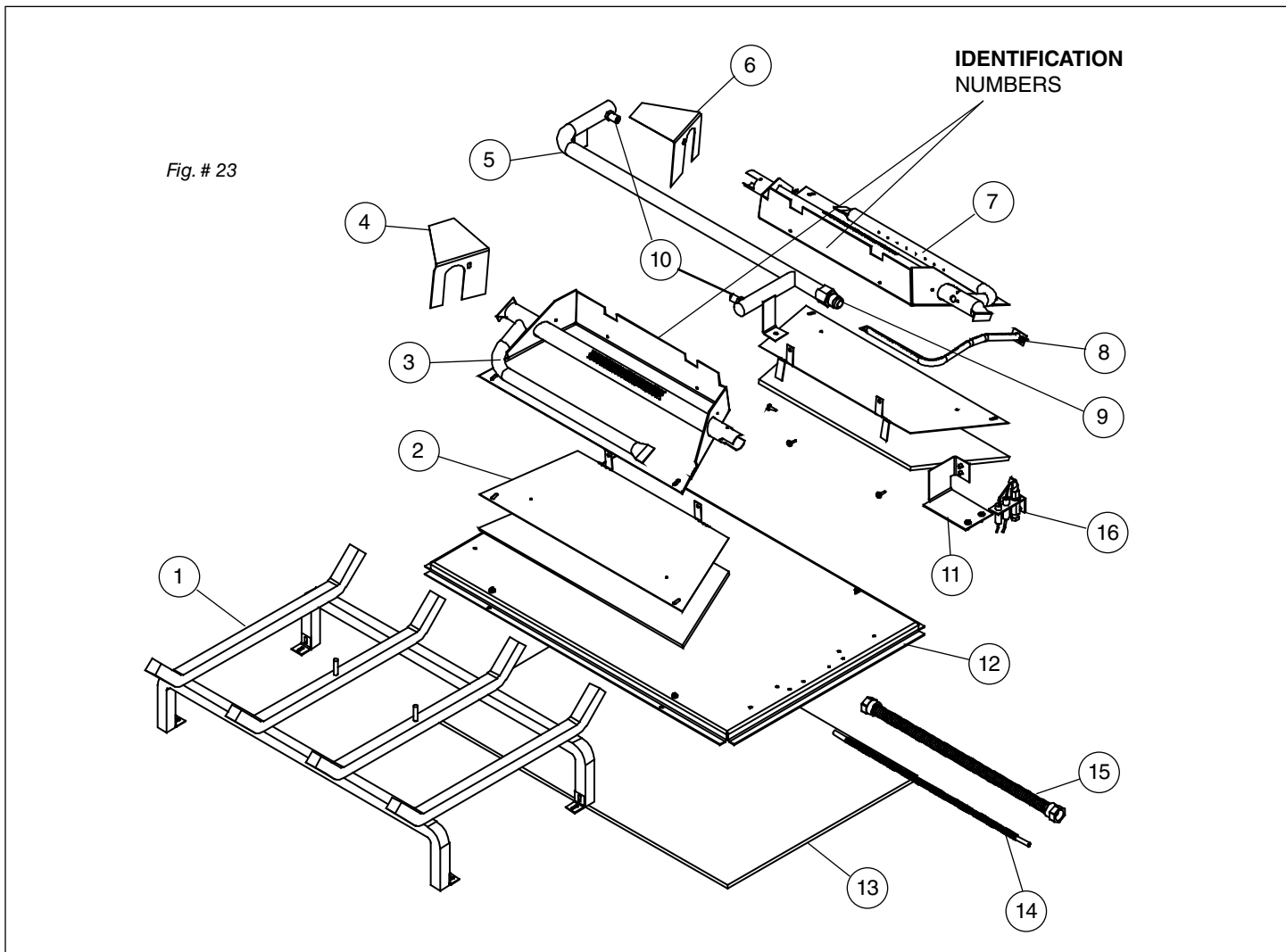

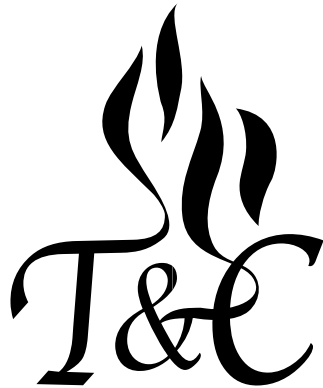

TOWN & COUNTRY  
FIREPLACES™

**TECHNICAL SUPPORT: 1-250-748-1184**  
**[www.townandcountryfireplaces.net](http://www.townandcountryfireplaces.net)**  
**2975 Allenby Rd., Duncan, BC V9L 6V8**