

**IMPORTANT:
THESE INSTRUCTIONS ARE TO REMAIN
WITH THE APPLIANCE INSTRUCTIONS**

These instructions are supplementary to the Installation and Operating Instructions supplied with the fireplace and should be kept together. Refer to the Installation and Operating Instructions for proper gas supply, safety requirements and operating instructions.



**TOWN & COUNTRY
FIREPLACES™**

**TC36 See-Thru
BLACK DIAMOND
BURNER KIT**



**PART#TC36.NGST03.C
FOR TC36
SEE-THRU
SERIES C**



Package Contents

1 BURNER TUBE	TC36.50118398
1 SHUTTER CONTROL ROD	5002.9692
1 BURNER TRAY ASSEMBLY	TC36.9690
2 BURNER SHIELD, FRONT/REAR	TC36.9693PBK
1 LEFT BURNER SHIELD.....	TC36.9693.2PBK
1 RIGHT BURNER SHIELD.....	TC36.9693.5PBK
1 AIR CHANNEL INSERT	TC36.9697PBK
1 LINE COVER	TC36.9699PBKA
1 PILOT SHIELD.....	TC36.9626PBK
1 MANIFOLD ASSEMBLY.....	TC36.9692
2 MEDIA SPACER, FRONT/REAR	9695
1 MEDIA SPACER, CENTER	9694
1 TUMBLED GLASS MEDIA.....	5012.01
1 HARDWARE PACKAGE	TC36.STHK03
1 PILOT ASSEMBLY.....	5005.025
1 1/4" FLEX COMPRESSION	5019.225
1 1/2" FLEX FLARE CONNECTION.....	5019.223

Fig. # 1

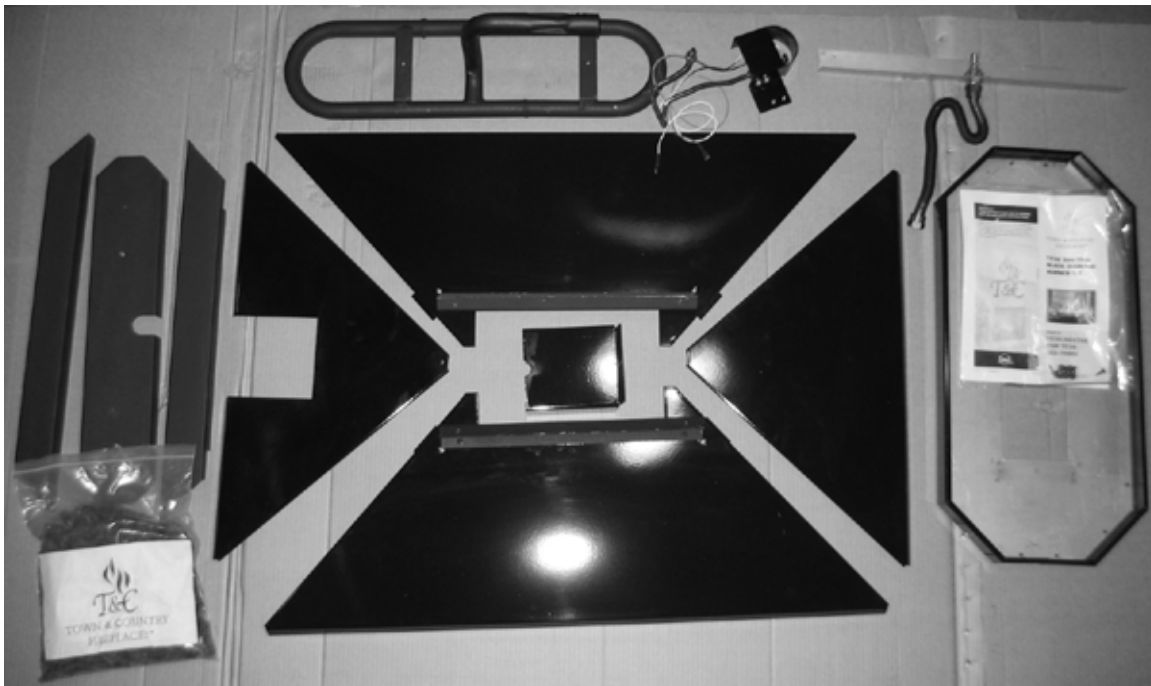

Black Diamond Burner Installation



Fig. # 2

NOTE: For the purposes of these instructions the controls and gas connections are on the right hand side of the unit.

Remove porcelain panels if they are installed.

1. Position the air channel insert into the air channel. (Fig. #2)



Fig. # 3

2. Remove the panel retainer clip located on the upper heat shield, install the left panel securing with panel retainer clip previously removed. (Fig. #3)

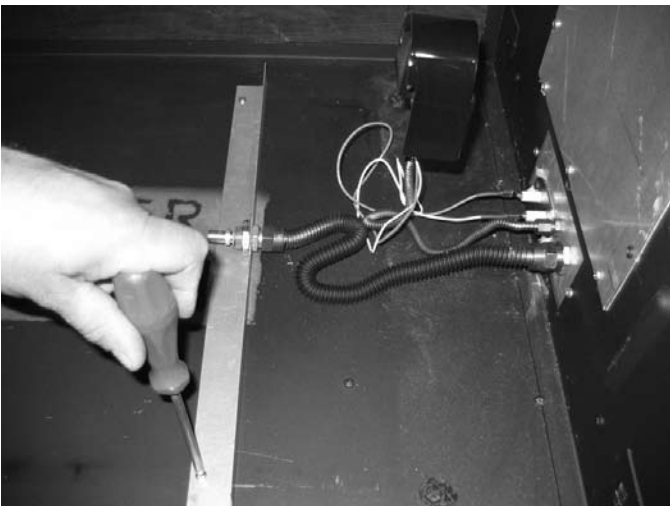

Fig. # 4

3. Attach the manifold assembly to the floor of the firebox using two screws. Seal the remaining holes in the floor of the fireplace with screws. (Fig. #4).
4. Connect the manifold flex gas line and pilot flex gas line to the bulkhead ensuring a gas-tight connection.

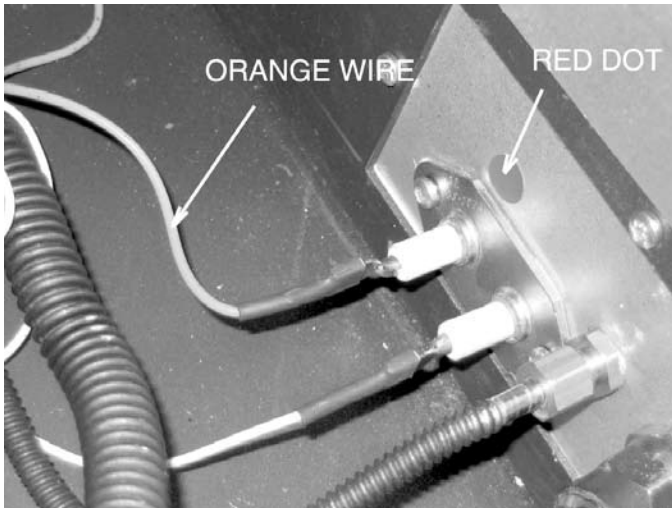

Fig. # 5

5. Connect the pilot electrical leads to the bulkhead. The orange ignitor wire goes to the connector at the rear of the bulkhead (marked with a red dot Fig. #5).

NOTE: If converting to propane fuel refer to page 9 before continuing.

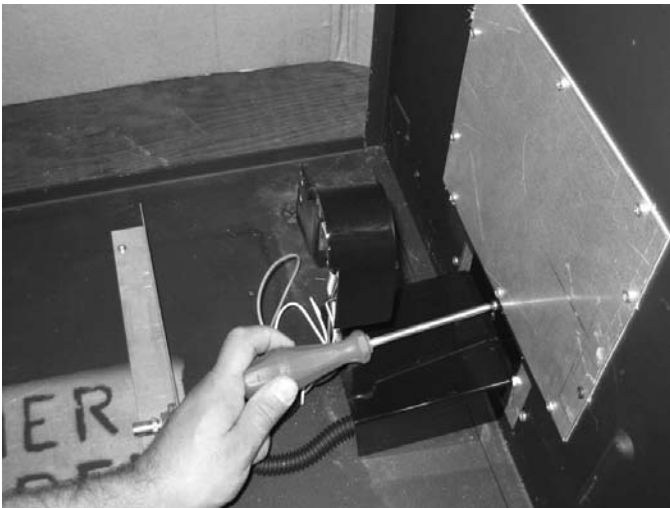

Fig. # 6

6. Attach the inlet cover using the top screw of the bulkhead (Fig. #6). Install the right porcelain panel (as in Fig. #3).

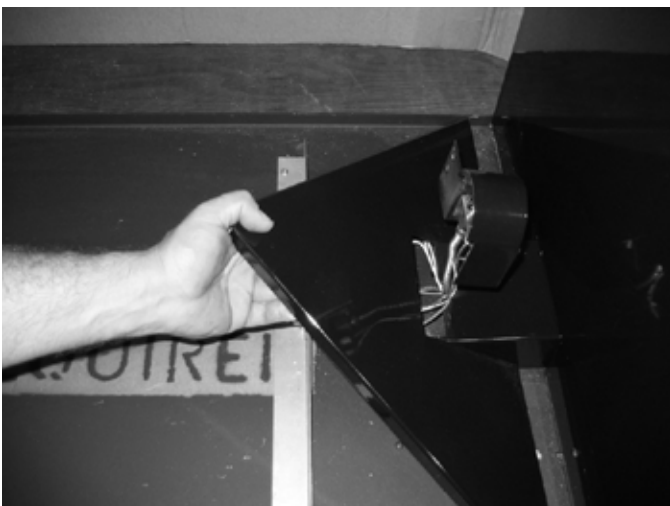

Fig. # 7

7. Position the right burner shield over the inlet cover ensuring that the pilot assembly is protruding through the half-hole between the inlet cover and the right burner shield (Fig. #7).

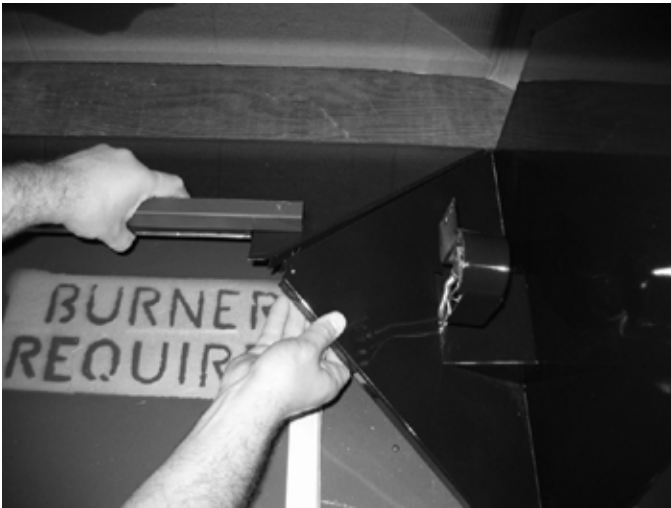

Fig. # 8

9. While supporting the right burner shield install the rear burner shield, resting the edge of the right burner shield onto the support tab of the rear burner shield (Fig. #8).



Fig. # 9

10. Install the front burner shield positioning the support tab under the right burner shield (Fig. #9).



Fig. # 10

11. Install the left burner shield. This will be a snug fit requiring some alignment (Fig. #10).

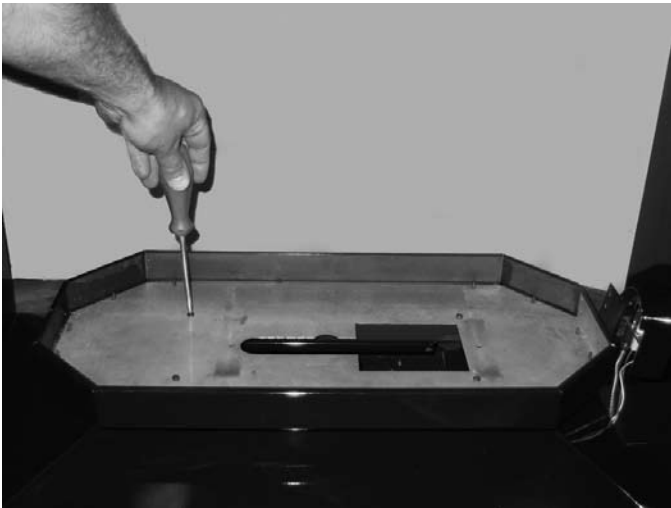

Fig. # 12

12. Position the burner tray assembly on top of the assembled shields and attach it using four screws (Fig. #12).

NOTE: Ensure that the square access hole of the tray is positioned to the right (control side).

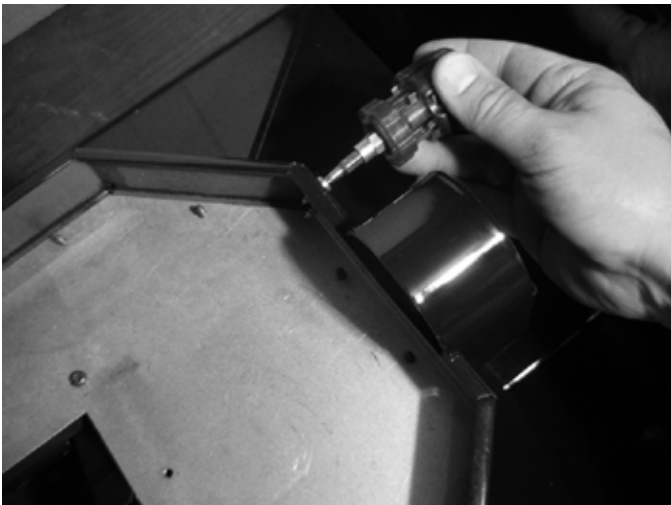

Fig. # 13

13. Attach the pilot assembly to burner tray using two screws (Fig. #13).



Fig. # 14

14. Position a front/rear media spacer at the rear of the burner tray (Fig. #14).



Fig. # 15

15. Position the other at the front of the tray (Fig. #15).



Fig. # 16

16. Loosen the screw on the burner tube shutter enough to allow smooth movement from open to closed positions (visible in Fig. #17).
14. Install the burner tube by tipping the inlet into the slot in the bottom of the burner tray (Fig. #16).



Fig. # 17

15. Hold the burner tube in a position so that the shutter control rod can be inserted into the shutter tab (Fig. #17) after passing through the rod hole in the top right corner of the front burner shield. (See Fig. #33).
16. Set the burner tube into place ensuring that it slips over the orifice on the manifold assembly. Align the attachment holes line up with the holes in the tray.

NOTE: Shutter must be fully open for propane or fully closed for natural gas (push down on the shutter control rod to open, pull up to close). Some adjustment may be required (see page 13).

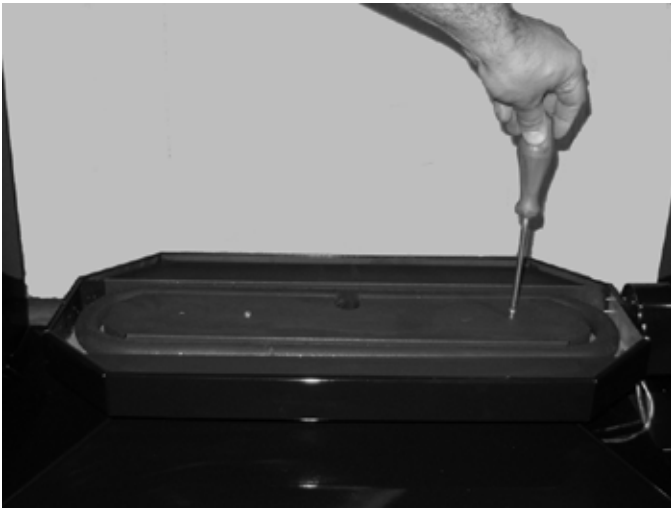

Fig. # 18

17. Position the center media spacer on the inside of the burner tube and attach using two long screws (Fig. #18).



Fig. # 19

18. Empty the contents of the supplied tumbled glass bag onto the burner tray (Fig. #19) and spread the glass evenly over top of the tube and media spacers (Fig. #20).

NOTE: Too much tumbled glass over the burner will cause sooting.



Fig. # 20

Propane Conversion

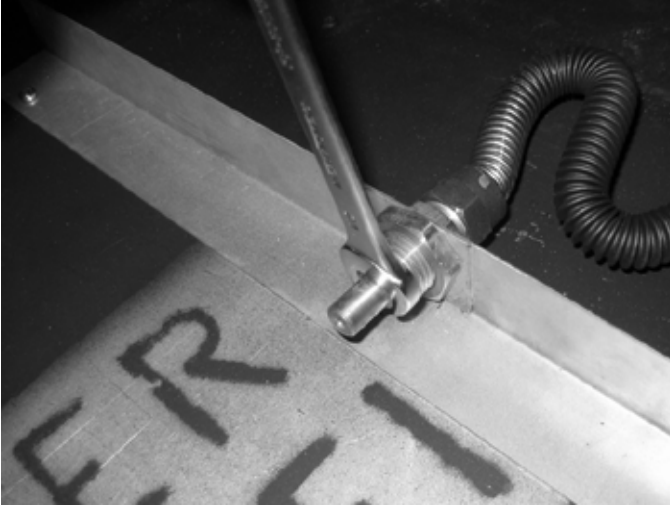

Fig. # 21

If the unit is to be used on propane convert as follows using the components supplied with this fireplace:

WARNING

This conversion kit shall be installed by a qualified service agency in accordance with the manufacturer's instructions and all applicable codes and requirements of the authority having jurisdiction. If the information in these instructions is not followed exactly, a fire, explosion or production of carbon monoxide may result causing property damage, personal injury or loss of life. The qualified service agency is responsible for the proper installation of this kit. The installation is not proper and complete until the operation of the converted appliance is checked as specified in the manufacturer's instructions supplied with the kit.

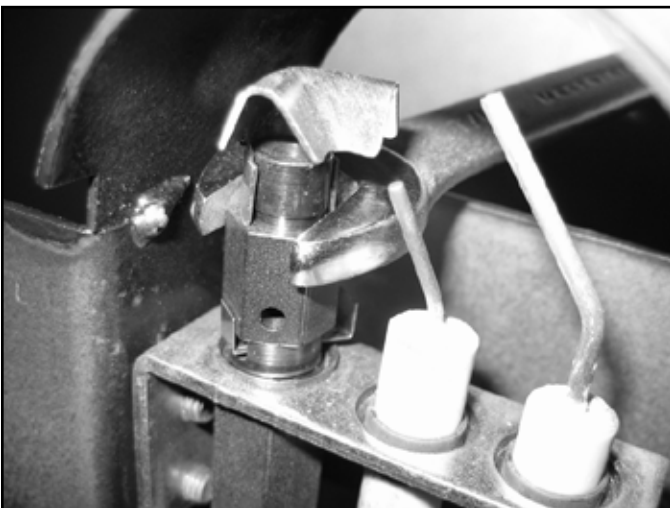

Fig. # 22

CAUTION

The gas supply and electrical power shall be shut off before proceeding with the conversion.

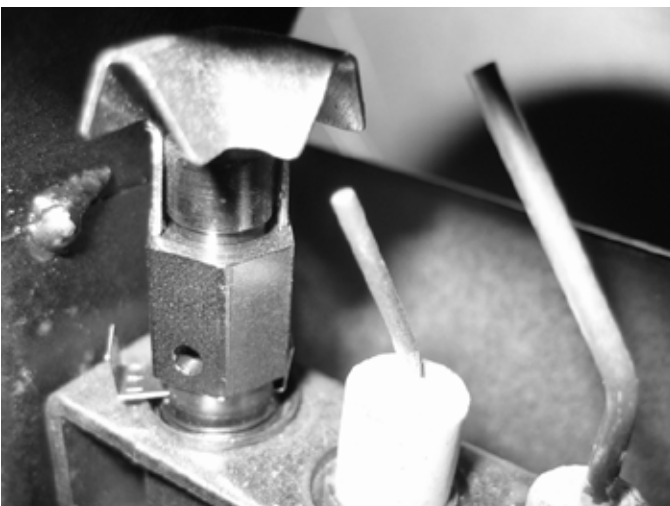

Fig. # 23

Remove the #25 orifice from the manifold assembly with a 1/2" wrench (Fig. #21).

Use a small amount of pipe thread compound to the threads of the 3/32" orifice to ensure a good seal before threading into the manifold assembly.

Open the shutter fully.

Using a 7/16" wrench loosen the pilot head on the pilot assembly.

Slide the pilot adjustment plate over and ensure that the hole in the plate is showing (Fig. #23 indicates NG position, Fig. #24 indicates LP position).

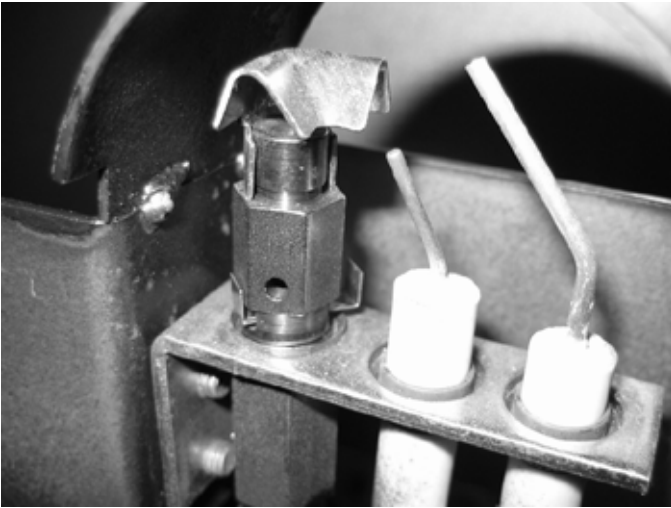

Fig. # 24



Fig. # 25

- 13) Remove access panel, 10 screws, and set aside (Seen in Fig. #29).
- 14) Remove the minimum rate screw located in the valve. (Fig. #25)

The minimum rate screw is sealed with an o-ring near the bottom of the screw. Use a thin bladed screwdriver to back the screw out past the limit of the threading. At this point a groove on the screw body will be visible just above the valve body. Insert a thin tool (knife blade or fine screwdriver blade) into the groove and gently pry the screw up. It helps to rotate the screw while lifting on it.



Fig. # 26

- 15) Replace the minimum rate screw with the one provided in the propane conversion kit supplied with this fireplace. Ensure that the screw is fully installed. (Fig. #26)



Fig. # 27

- 16) Pull off the rubber cap from the top of the pressure regulator. (Fig. #27)

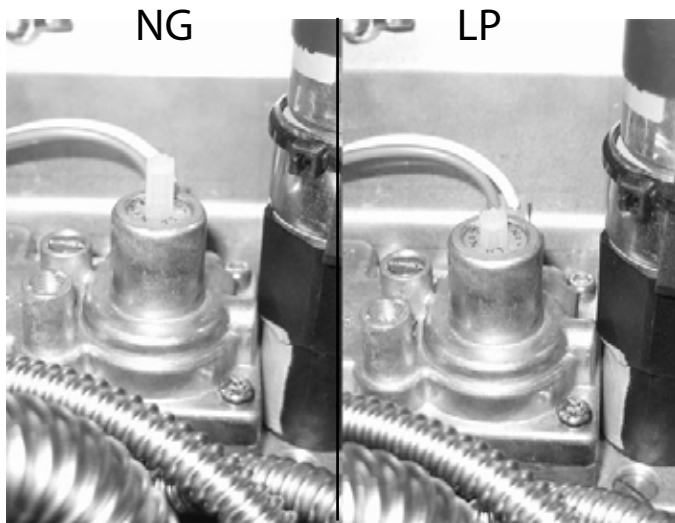

Fig. # 28

- 17) Press down on the center post and rotate 90°. The center post should stay down. (Fig. #28). Replace the rubber cap.
- 18) Fill in the date and the name of the person who performed the conversion in the white area on the conversion label. Peel off the protective backing and apply the conversion label directly over the gas specifications on the rating label.

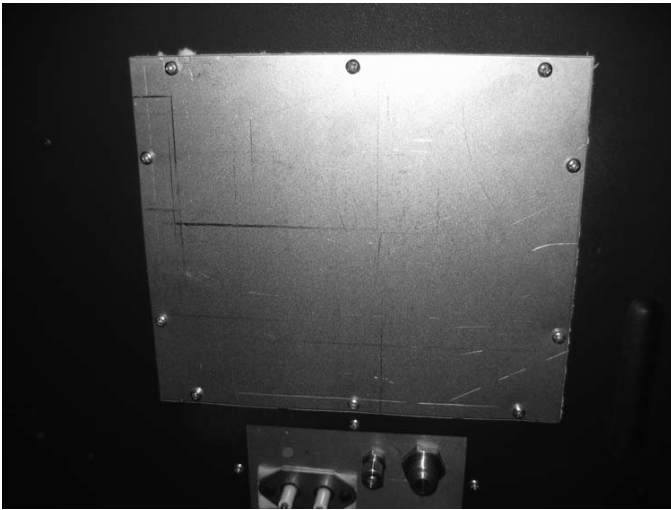

Fig. # 29

- 19) Attach the access panel to the side of the firebox with the previously removed screws. (Fig. #29)

Note: Gasket must be installed with access panel.

Gas Pressure Check

Fig. # 30

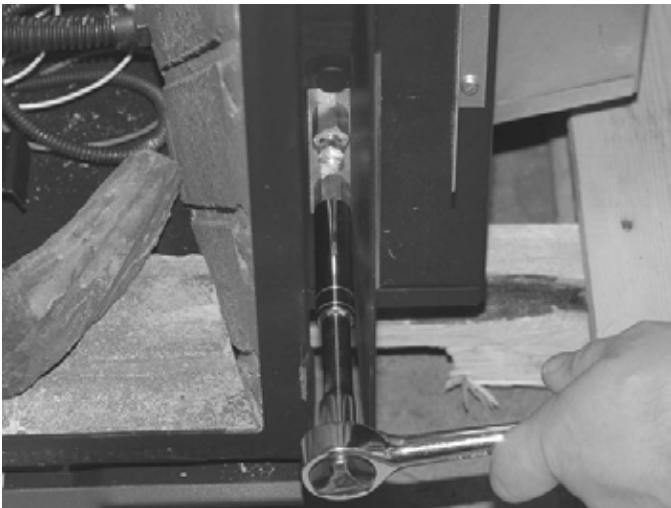

Note: To test the gas pressure, turn off the gas supply before removing the blanking plug from the pressure test port. Verify gas pressures with the fireplace lit and on the highest setting.

- 1) Remove the blanking plug from the pressure test port. The plug is located between the right side lintel and firebox side. (Fig. #30)

CORRECT GAS PRESSURE REQUIREMENT:

Supply Pressure (For purpose of input adjustment)	Natural Gas	Propane
Minimum	5.0" wc	12.5" wc
Maximum	13.9" wc	13.9" wc

Manifold pressure

Maximum	3.8" wc	11.0" wc
Minimum	2.1" wc	5.5" wc

Fig. # 31



- 2) Thread the extension test fitting into the open port. (Fig. #31)
- 3) Attach a pressure gauge onto the fitting.
- 4) When testing is complete shut of the gas, remove the fitting and replace the plug. Thread sealant will be required to ensure a gas tight connection.

Burner Flame Adjustment

The air shutter on the burner tube controls the primary combustion air. It is set to the closed position at the factory for natural gas fuel. Some adjustment may be necessary to obtain desired flame and to eliminate carbon deposits. Evaluate flame appearance after the fireplace has reached operating temperature. See Fig. #32 for proper flame pattern.

Open primary air if the window glass and firebox have carbon accumulation and/or the flames are long, dark and stringy. The shutter may also be opened to lessen the flame height.

CAUTION:

Burner area may be hot!

Turn off the fireplace and allow the unit to cool before proceeding.

To adjust: (See Fig. #33)

Push the shutter control rod to increase the amount of primary air to create a more blue flame.

Pull the shutter to decrease the amount of primary air to create a more yellow flame.

NOTE:

Proper air shutter setting is required.

The flame should be just orange and "lazy". It should NEVER be set to create sooting on internal parts and window glass.



Fig. # 32

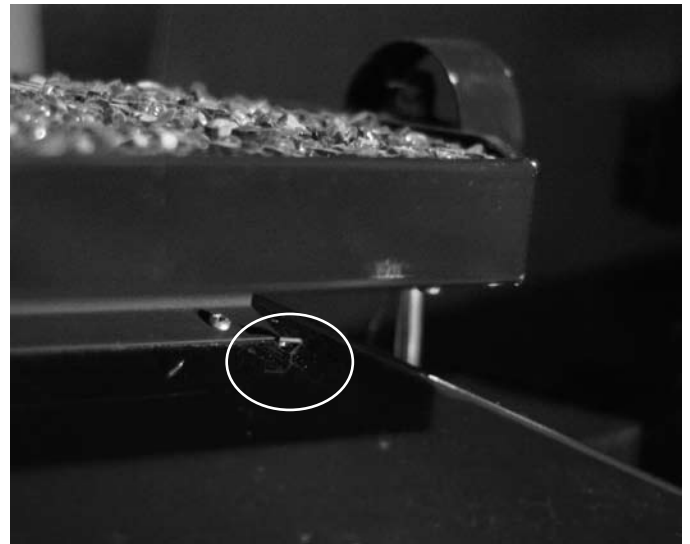
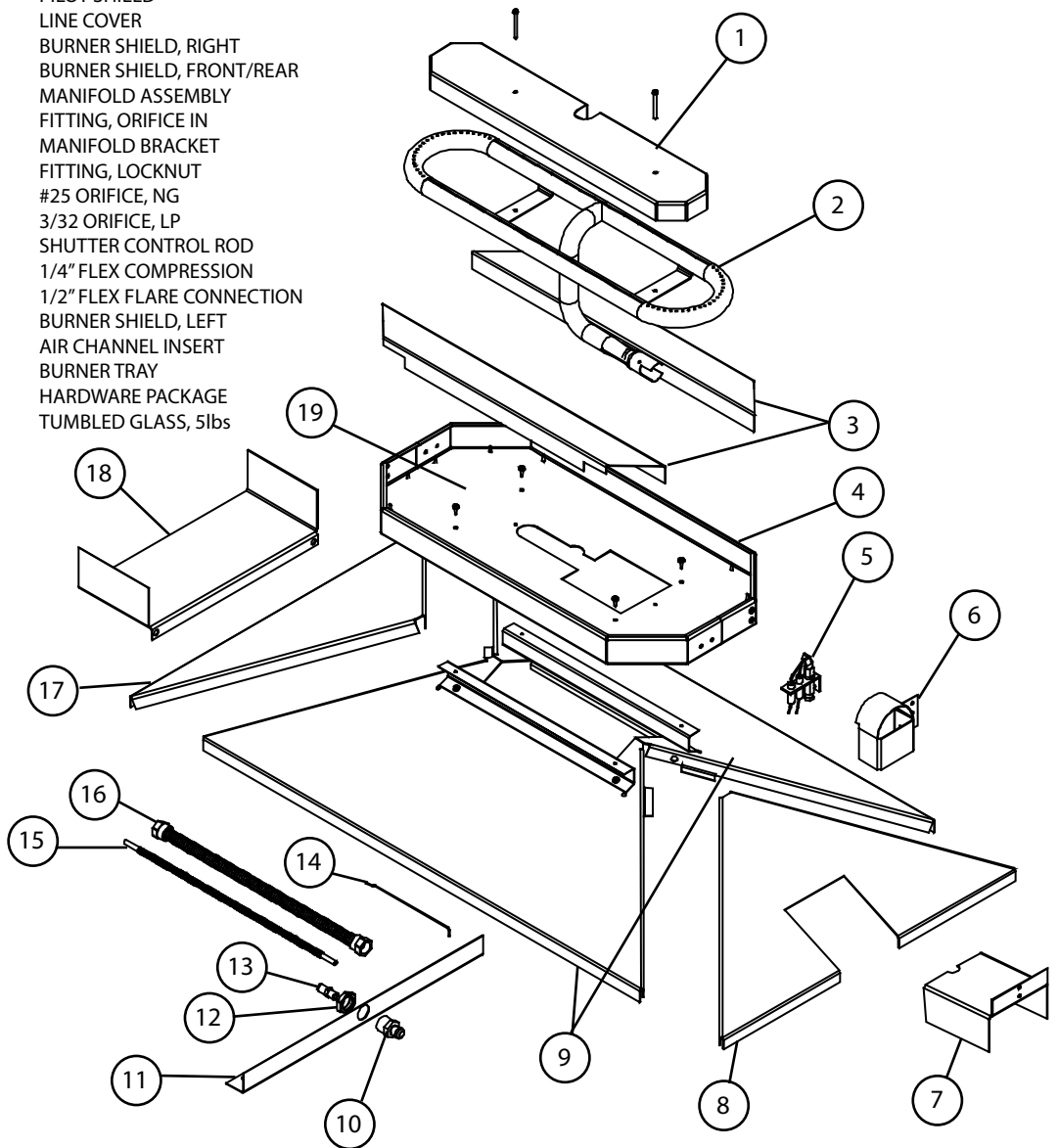

Fig. # 33

Replacement Parts

NOTE:
 FIREPLACE & VALVE REPLACEMENT
 PARTS ARE LOCATED IN THE
 APPLIANCE INSTRUCTIONS

ITEM	PART NUMBER	DESCRIPTION
1	9694	MEDIA SPACER, CENTER
2	TC36.50118398	BURNER TUBE
3	9695	MEDIA SPACER, FRONT/REAR
4	9690.5	TRAY TRIM
5	5005.025	PILOT ASSEMBLY
6	9626.002	PILOT SHIELD
7	TC36.9699PBKA	LINE COVER
8	9693.5	BURNER SHIELD, RIGHT
9	9693	BURNER SHIELD, FRONT/REAR
.....	TC36.9692	MANIFOLD ASSEMBLY
..10	5019.21	FITTING, ORIFICE IN
..11	9692	MANIFOLD BRACKET
..12	5021.01	FITTING, LOCKNUT
..13	5022.12	#25 ORIFICE, NG
	5021.31	3/32 ORIFICE, LP
14	5002.9692	SHUTTER CONTROL ROD
15	5019.225	1/4" FLEX COMPRESSION
16	5019.223	1/2" FLEX FLARE CONNECTION
17	9693.2	BURNER SHIELD, LEFT
18	9697	AIR CHANNEL INSERT
19	9690	BURNER TRAY
	TC36.STHK03	HARDWARE PACKAGE
	5012.01	TUMBLER GLASS, 5lbs





TOWN & COUNTRY
FIREPLACES™

TOWN & COUNTRY FIREPLACES

Technical Support: 1-877-715-2664

www.townandcountryfireplaces.net

2975 Allenby Rod, Duncan, BC Canada V9L 6V8