

**INSTALLER: Leave this manual with the appliance.
CONSUMER: Retain this manual for future reference.**

These instructions are supplementary to the Installation and Operating Instructions supplied with the fireplace and should be kept together. Refer to the Installation and Operating Instructions for proper gas supply, safety requirements and operating instructions



**TOWN & COUNTRY
FIREPLACES™**

TC42 COUNTRY HOME BURNER KIT INSTRUCTIONS



**PART#
TC42.NG02.C
FOR TC42**



Contents of Package

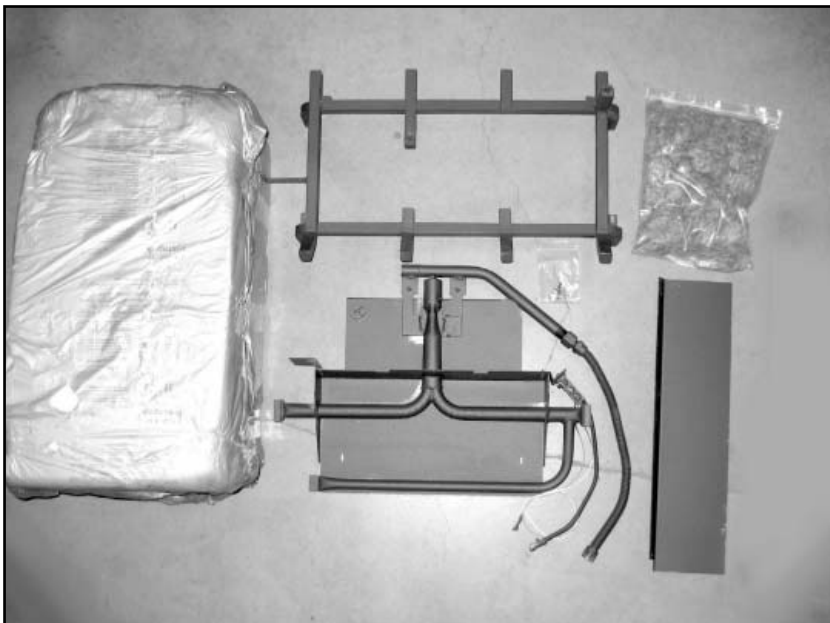

- BURNER ASSEMBLY (including pilot and manifold)
- LOG GRATE
- TC42 LOGS
- EMBER MATERIAL
- HARDWARE PACKAGE
- AIR DEFLECTOR

Burner/ Grate Installation

Fig. # 1

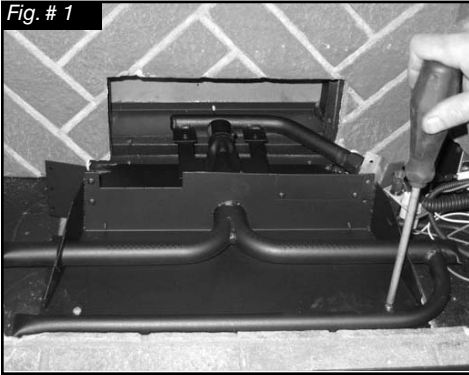

1. Attach the burner assembly to the floor of the firebox with two screws. (Fig. # 1)

Fig. # 2

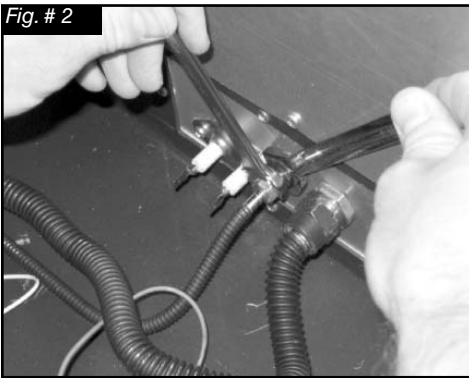

2. Connect flex lines from the manifold and pilot assemblies to the bulkhead in the firebox side. (Fig. # 2) Ensure that the connection is gas tight.

Fig. # 3

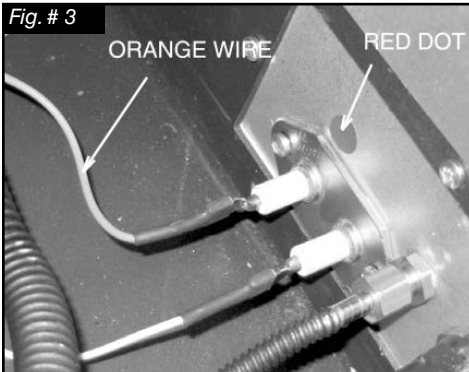

3. Attach spark electrode (ORANGE) and sensor leads to the electrical bulk head. (Fig. # 3) (The spark electrode connection has a red dot above it)

A panel set must now be installed. See Installation and Operating Instructions manual for details.

Fig. # 4



4. Position the grate in the slots of the burner tray and attach to the floor with two screws through holes located behind the front legs of the grate. (Fig. # 4)
5. Attach rear deflector to rear of grate using the two screws provided. (Fig. # 5)

Ember Material Placement

A large bag of ember material is shipped with the fireplace and needs to be installed to ensure optimum performance and flame appearance.

Pull apart the material into ember size pieces (approximately 1" squares) and gently place them into the burner pan. Do not compress, leave it loose for best performance.

Fill the burner pan level with the top of the pan at rear, and gradually slope forward to the firebox floor at the front, covering both burner tubes.

Place remaining ember material outside of the burner pan as desired to cover-up gas lines and brackets.

Note: Ember material placement and amount will affect flame appearance. More ember material results in lower flame height. Add or remove as needed until desired flame affect is achieved.

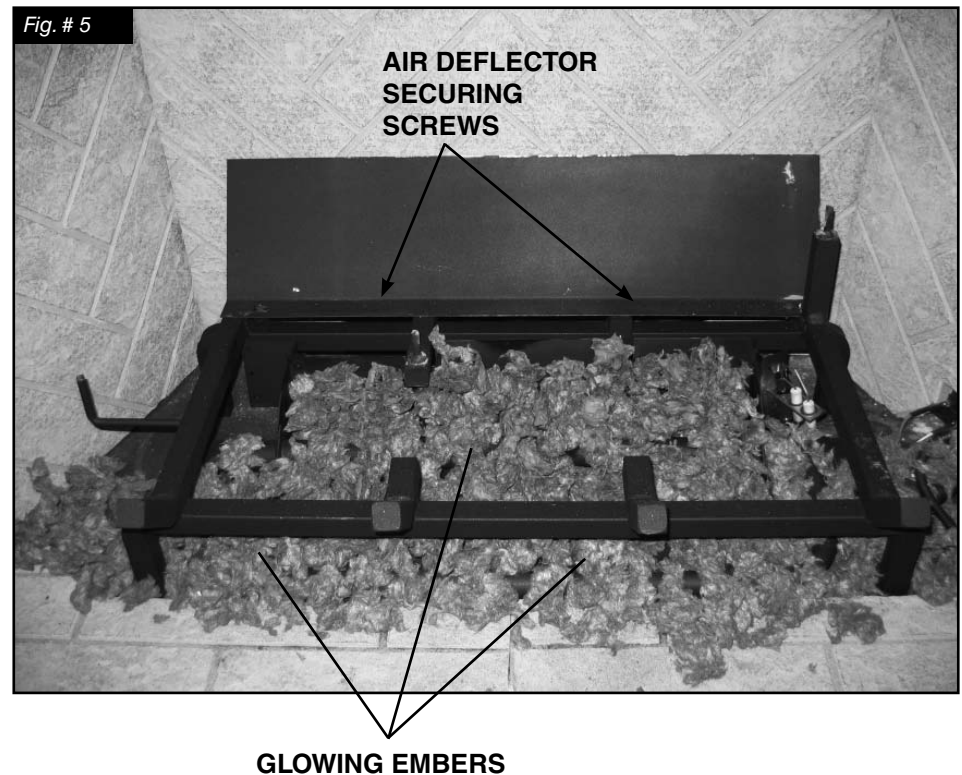

Log Placement

Gas plumbing and vent connections should be completed before proceeding.

The logs are fragile, and should be handled with care. Unpack and inspect log set. There should be a total of seven logs.

Note: The #2 left log has only one pin location at the top. The lower part of the log rests between the grate and the "L" shaped rod on the left of the grate

Position the logs as indicated by the following pictures. The three main logs have holes and / or pins. Engage each pin in the corresponding holes. The four smaller logs do not have holes or pins. They rest in position. Locate as per the diagrams (fig. # 6-12).

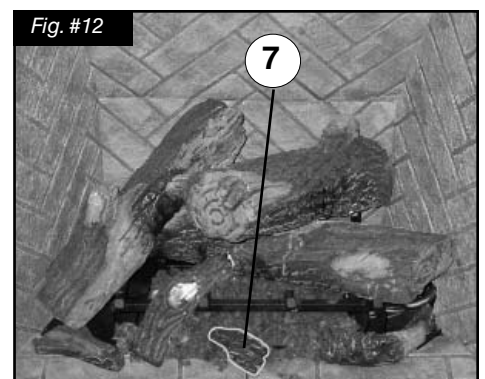
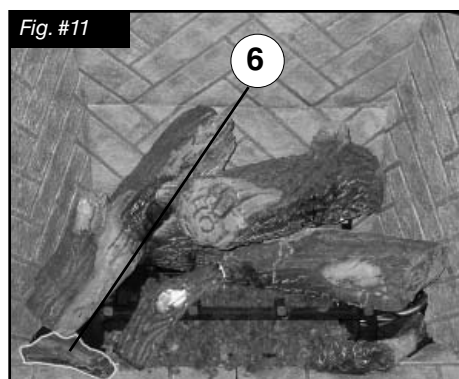
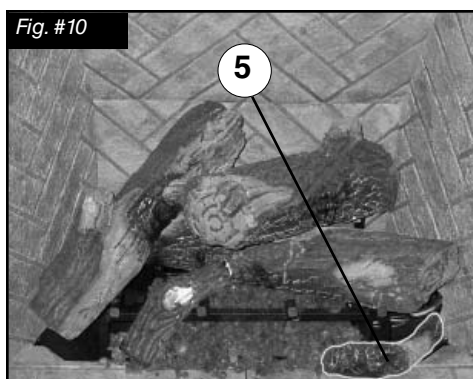
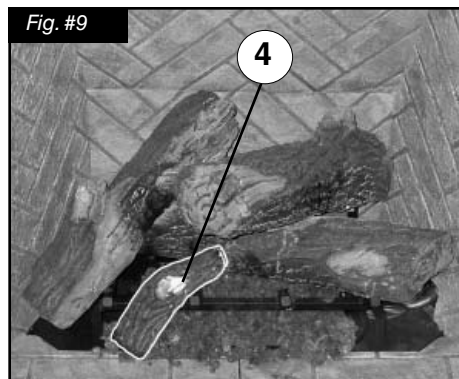
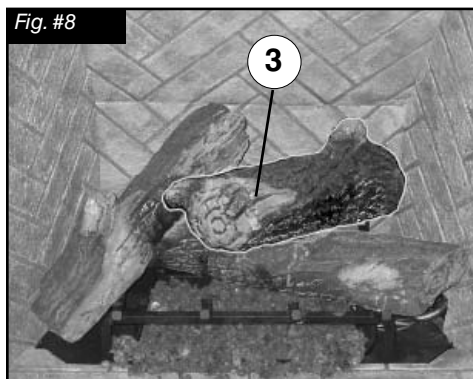
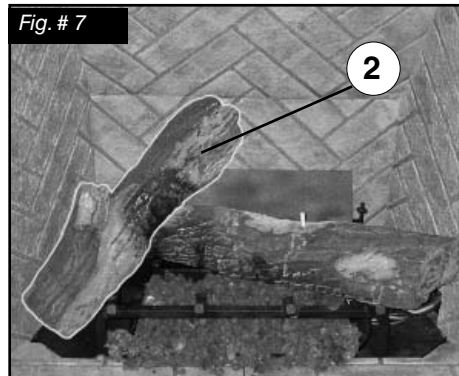
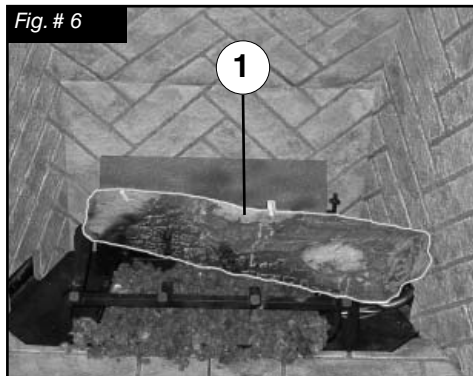

Note: Improper placement of logs will cause sooting on internal parts and glass. The logs may need to be repositioned slightly to avoid excessive flame impingement.

Propane Conversion

WARNING

This conversion kit shall be installed by a qualified service agency in accordance with the manufacturer's instructions and all applicable codes and requirements of the authority having jurisdiction.

If the information in these instructions is not followed exactly, a fire, explosion or production of carbon monoxide may result causing property damage, personal injury or loss of life.

The qualified service agency is responsible for the proper installation of this kit.

The installation is not proper and complete until the operation of the converted appliance is checked as specified in the manufacturer's instructions supplied with the kit.

If the unit is to be used on propane convert as follows using the components supplied with this fireplace:

Note: Factory supplied components must be used to ensure correct input. After conversion confirm proper manifold pressure.

1. Ensure the burner, pilot and gas supply are turned off, and the appliance has cooled.
2. Remove the two screws securing the air deflector to the burner grate. (Fig. #13)
3. Remove the two screws securing the manifold assembly to the burner. (Fig. #14)
4. Remove the manifold assembly from the burner. (Fig. #15)



5. With a 1/2" wrench remove the natural gas orifice (#25) and replace with propane orifice (3/32")(our part # 5021.31) (Fig. #16)
6. Fully open the primary air shutter.
7. Reinstall the manifold and air deflector.

CAUTION

The gas supply and electrical power shall be shut off before proceeding with the conversion.

Fig. # 17

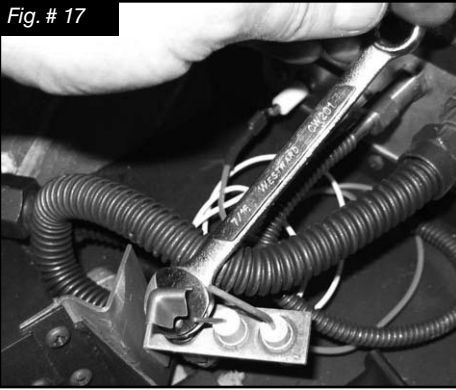

8. With a 7/16" wrench loosen the pilot head on the pilot assembly by a half-turn (Fig. #17)

Fig. # 18



9. Slide the pilot adjustment band over and ensure that the hole in the orifice band is showing. (Fig. #18 shows NG position, Fig. # 19 shows LP position)

Fig. #19



Fig. # 20

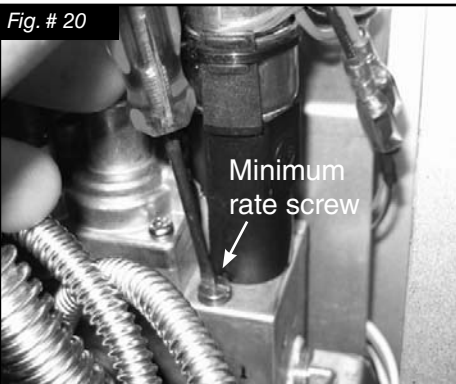

10. Remove the minimum rate screw located in the valve. (Fig. #20)

11. Replace the minimum rate screw with the one provided in the propane conversion kit supplied with this fireplace. Ensure that the screw is fully installed. (Fig. #21)

Fig #21



- Pull off the rubber cap from the top of the pressure regulator. (Fig. #22)



- Press down on the center post and rotate 90°. The center post should stay down. (Fig. #23). Replace the rubber cap.

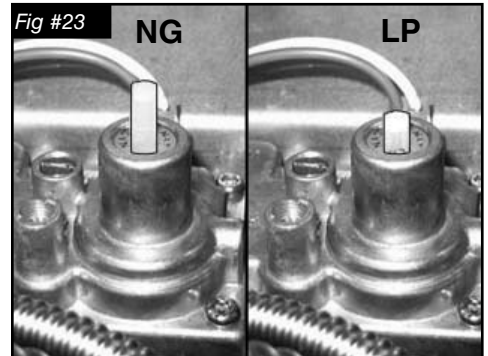

ADD DATE

ADD NAME

Fig #23a

This kit is for use with model / TC36.NGST03.C.
 Pour utilise avec du modèle: TC36.NGST04.C &TC42

Date: _____

By / Par: _____ **PACIFIC ENERGY**

LP GAS/ DU GAZ LP	This appliance was converted to PROPANE GAS with this kit on this date by the organization which accepts the responsibility that this conversion has been properly made. / Cet appareil etair convertir au gaz LP par l'emploi de la trousse de conversion par une organization qui accepte la responsabilité pour une installation en bon état.
12.5 in/wc /12.5 po/c.e. (3.11 kPa)	
13.9 in/wc / 13.9 po/c.e. (3.45 kPa)	
11.0 in/wc / 11.0 po/c.e. (.95 kPa)	
3/32" (2.38 mm)	
Max.: 61,000 (17.9)	
Min.: 46,200 (13.5)	

120906 6-TC42C 5052.5206.C

- Fill in the date and the name of the person who performed the conversion in the white area on the conversion label. Peel off the protective backing and apply the conversion label directly over the gas specifications on the rating label.

WARNING

The access panel including gasket must be reinstalled after conversion/ installation or servicing has been completed.

Failure to do so will overheat and cause premature failure of the control system.

- Attach the access panel to the side of the firebox with the previously removed screws. (Fig. #24)

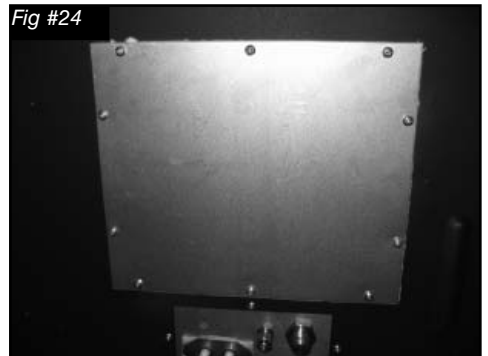

Gas Pressure Check

Note: To test the gas pressure, turn off the gas supply before removing the plug from the supply pressure test port or manifold pressure test port.

Verify gas pressures with the fireplace lit and on the highest setting.

Fig #25



1. Remove the pressure test port plug from the manifold test port. The plug is located between the right side lintel and firebox side (bottom port). (Fig. #25)

Fig #26



2. Thread the extension test fitting into the open test port. (Fig. #26)
3. Attach a pressure gauge onto the fitting.
4. When testing is complete remove the extension test fitting and replace the plug. Thread sealant will be required to ensure a gas tight connection.

Correct gas pressure requirement:

Supply Pressure <small>(For purpose of input adjustment)</small>	Natural Gas	Propane
Minimum	5.0" WC	12.5" WC
Maximum	13.9" WC	13.9" WC
Manifold Pressure		
Maximum	3.8" WC	11" WC
Minimum	2.1" WC	5.5" WC

Burner Flame Adjustment

The air shutter on the burner tube controls the primary combustion air to the gas burner and is pre-set closed at the factory for natural gas fuel. Propane requires fully open shutter setting. Some adjustment may be necessary to obtain desired flame and to eliminate carbon deposits. Evaluate flame appearance after the fireplace has reached operating temperature. See Fig. #27 for proper flame pattern.

Open primary air shutter if the logs, glass, and firebox have carbon accumulation and / or the flames are long, dark and stringy. The shutter may also be opened to enhance the Ember Material glow and lessen the flame height.

Caution: Burner area may be hot!

Turn off the fireplace and allow the unit to cool before proceeding.



Caution: Proper air shutter setting is a must.

The flame should be just orange and “lazy”. It should NEVER be set to create sooting on internal parts and glass.

To Adjust: (See Fig. #28)

1. Open and remove window frame and set aside. See "Window Frame Removal" section found in the Installation and Operating Instructions manual.
2. Remove the log set and set aside.
3. Loosen the screw in the Primary Air Shutter.
4. Rotate the shutter to increase or decrease the amount of primary air.
5. Reassemble as needed

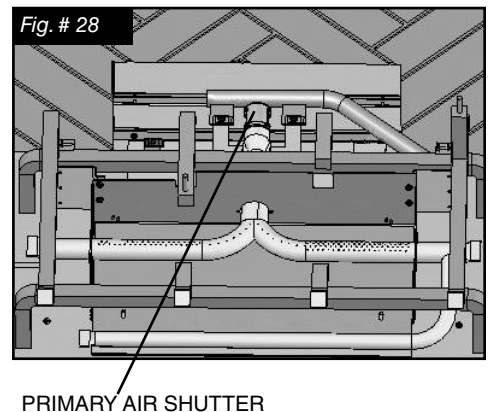

Replacement Parts TC42.NG02.C

(WHEN ORDERING, INCLUDE PART NUMBER WITH DESCRIPTION)

ITEM.....DESCRIPTION.....PART NO.

#1.....BURNER ASSEMBLY.....TC42.NG02.C

#2.....7 PCS LOG SET5098.311

#3.....ORIFICE, NATURAL GAS (#25).....5022.12

ITEM.....DESCRIPTION.....PART NO.

#4.....PILOT ASSEMBLY.....5005.025

#5.....MAIN SUPPLY TUBE.....5019.223

#6.....PILOT TUBE5019.225

* #7.....PROPANE CONVERSION KITTC42.LPCE01

* NOT SHOWN

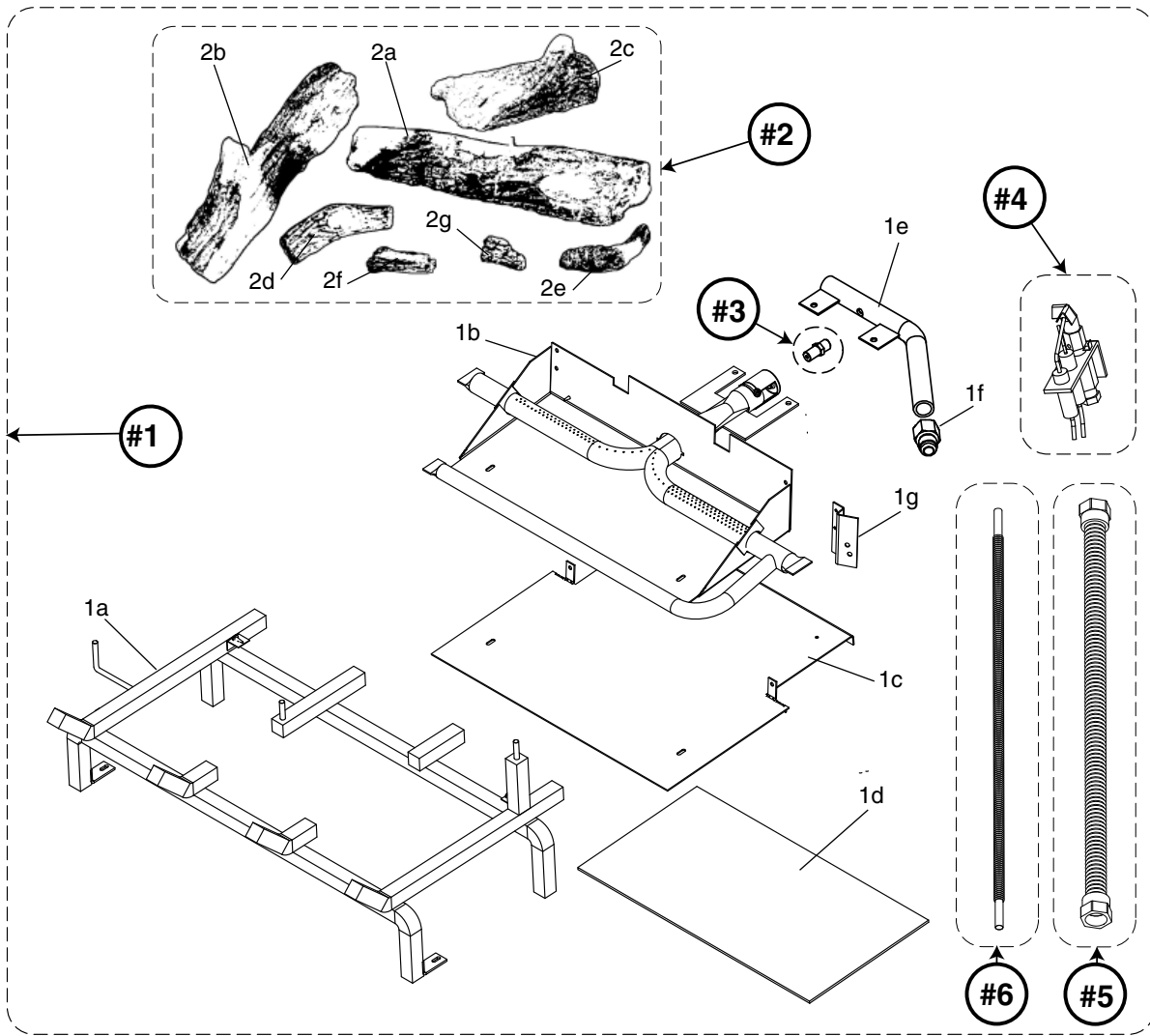

KIT CONTENTS:

#1.... BURNER ASSEMBLY

- 1a GRATE
- 1b BURNER TRAY
- 1c BURNER TRAY SUPPORT SHIELD
- 1d BURNER TRAY SHIELD GASKET
- 1e MANIFOLD
- 1f 1/2 PIPE TO 1/2 TUBE CONNECTION
- 1g PILOT BRACKET
- * AIR DEFLECTOR (Not shown)

2a LOG #1

- 2b LOG #2
- 2c LOG #3
- 2d LOG #4
- 2e LOG #5
- 2f LOG #6
- 2g LOG #7
- 3 ORIFICE, NATURAL GAS #25
- 4 PILOT ASSEMBLY
- 5 MAIN SUPPLY TUBE
- 6 PILOT TUBE

#2.... 7 PCS LOG SET

- 2a LOG #1
- 2b LOG #2
- 2c LOG #3
- 2d LOG #4
- 2e LOG #5
- 2f LOG #6
- 2g LOG #7

#3.... ORIFICE, NATURAL GAS (#25)

- #4.... PILOT ASSEMBLY, CONVERTIBLE
- #5.... MAIN SUPPLY TUBE
- #6.... PILOT TUBE
- #7.... PROPANE CONVERSION KIT (Not shown)



TOWN & COUNTRY
FIREPLACES™

TECHNICAL SUPPORT: 1-888-715-2664
www.townandcountryfireplaces.net
2975 Allenby Rd., Duncan, BC V9L 6V8