

**INSTALLER: Leave this manual with the appliance.  
CONSUMER: Retain this manual for future reference.**

These instructions are supplementary to the Installation and Operating Instructions supplied with the fireplace and should be kept together. Refer to the Installation and Operating Instructions for proper gas supply, safety requirements and operating instructions



**TOWN & COUNTRY  
FIREPLACES™**

## **TC42 CHALET II BURNER KIT INSTALLATION INSTRUCTIONS**



**PART#  
TC42.NG06.C  
FOR TC42**



## Contents of Package

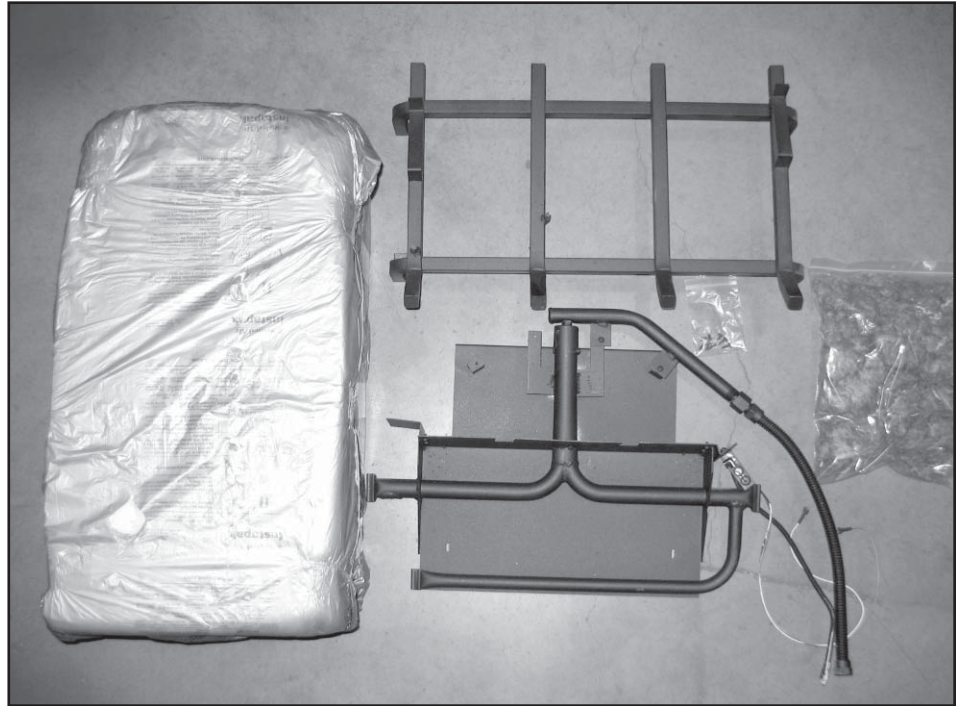

- BURNER ASSEMBLY
- LOG GRATE
- TC42 LOGS
- EMBER MATERIAL
- HARDWARE PACKAGE

# Burner/ Grate Installation

Fig. # 1



1. Attach the burner assembly to the floor of the firebox with two screws. (Fig. # 1)

Fig. # 2

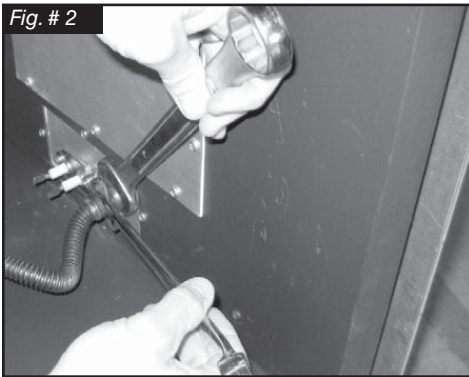

2. Attach the manifold supply tube to the bulk head fitting and tighten. (Fig. # 2) Ensure that there are no leaks.

Fig. # 3

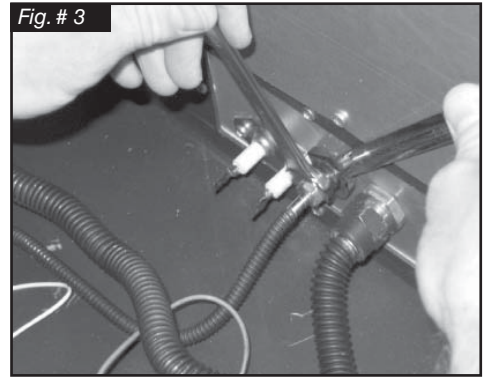

3. Attach the pilot supply tube to the bulk head fitting and tighten. (Fig. # 3) Ensure there are no leaks.

Fig. # 4

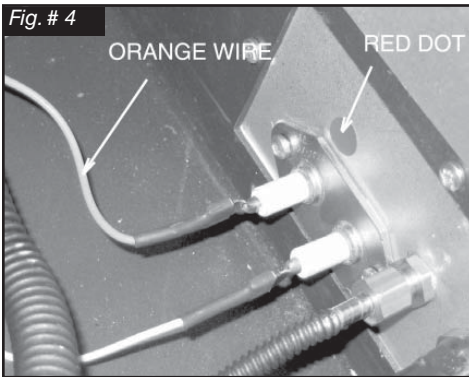

4. Attach spark electrode (ORANGE) and sensor leads to the electrical bulk head. (Fig. #4) (The spark electrode connection has a red dot above it)

**A panel set must now be installed. See Installation and Operating Instructions manual for details.**

Fig. # 5



5. Position the grate over the burner tray and attach to the floor with two screws through holes located behind the front legs of the grate. (Fig. # 5)

# Ember Material

A large bag of ember material is shipped with the fireplace and needs to be installed on the burner to ensure optimum performance and flame appearance.

1. Pull apart the material into ember size pieces (approximately 1" squares) and gently place them into the burner pan. Do not compress, leave them loose for best performance.
2. Fill the burner pan level with the top of the pan at rear, and gradually sloping forward down to the firebox floor at the front, covering both burner tubes.
3. Place remaining ember material outside of the burner pan as desired to cover-up gas lines and brackets.

**Note:**

**Ember material placement and amount will affect flame appearance. More ember material results in lower flame height. Add or remove as needed until desired flame affect.**

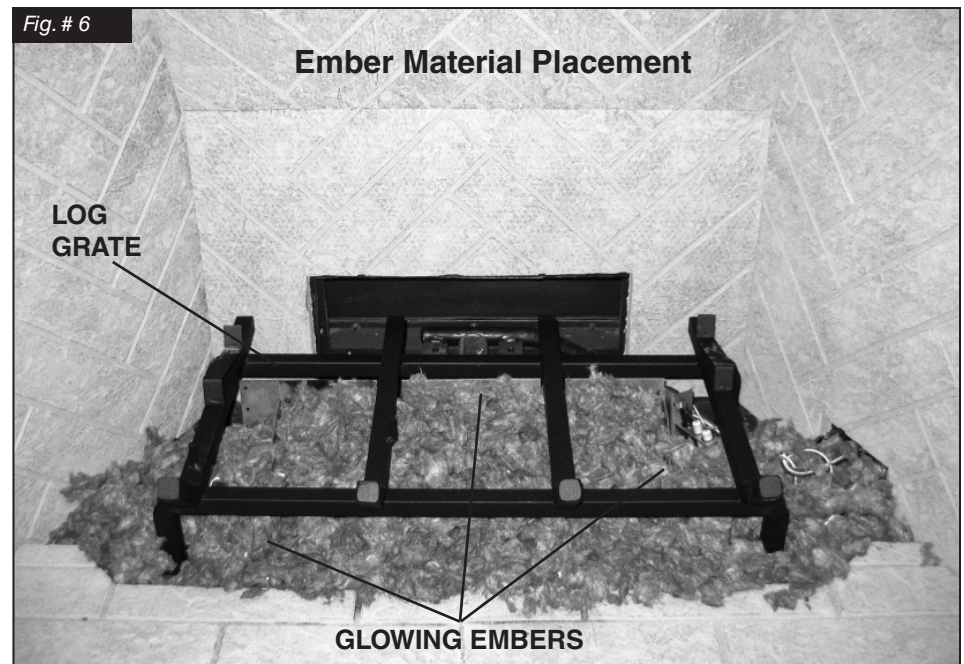

# Log Set Assembly

Gas plumbing and vent connections should be completed before proceeding.

The logs are fragile and should be handled with care. Unpack and inspect log set. There should be a total of 7 logs. Position the logs as indicated by the following pictures. Place the rear log back against the tabs located at the back of the grate. Place left log as pictured, engaging the pins with corresponding holes on the underside of the log. Install the right log into the grate and pull it forward into position as shown. Place the four remaining small logs on the floor of the firebox in the positions and order as shown.

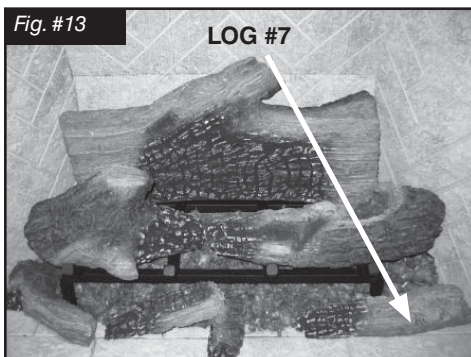
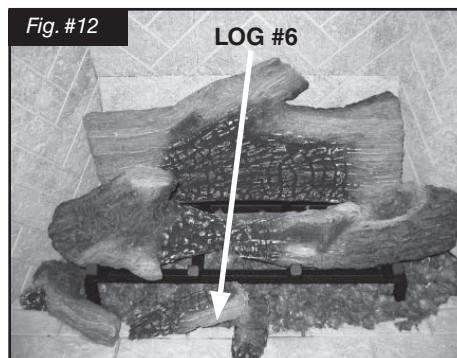
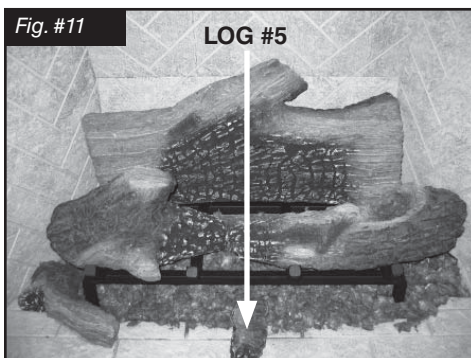
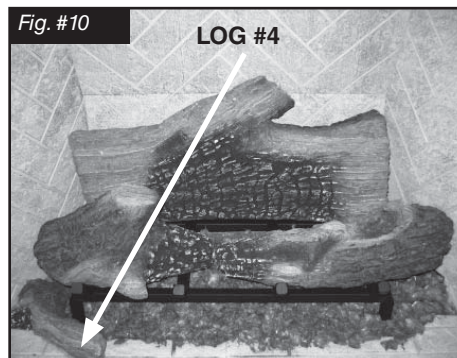
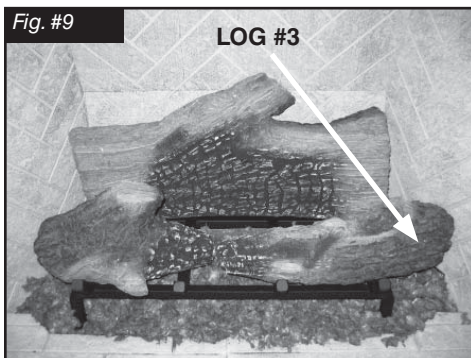
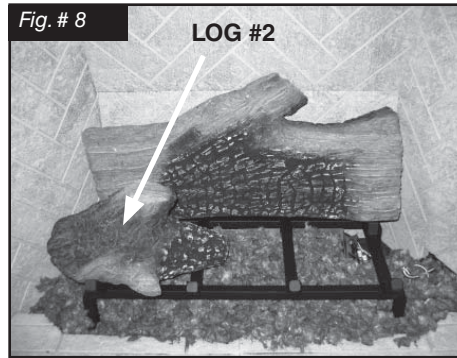
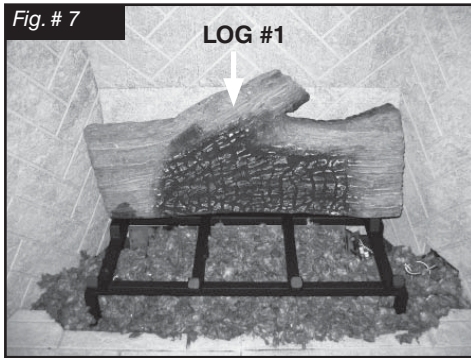

**Note: Improper placement of logs will cause sooting on internal parts and glass.**

# Propane Conversion

## WARNING

This conversion kit shall be installed by a qualified service agency in accordance with the manufacturer's instructions and all applicable codes and requirements of the authority having jurisdiction.

If the information in these instructions is not followed exactly, a fire, explosion or production of carbon monoxide may result causing property damage, personal injury or loss of life.

The qualified service agency is responsible for the proper installation of this kit.

The installation is not proper and complete until the operation of the converted appliance is checked as specified in the manufacturer's instructions supplied with the kit.

## CAUTION

The gas supply and electrical power must be shut off before proceeding with the conversion.

If the unit is to be used on propane, convert as follows using the components supplied with this fireplace:

Note: Factory supplied components must be used to ensure correct input. After conversion confirm proper manifold pressure.

1. Ensure the burner, pilot and gas supply are turned off, and the appliance has cooled.
2. Remove the two screws securing the manifold assembly to the burner. (Fig. #14)
3. Remove the manifold assembly from the burner. (Fig. #15)
4. With a  $\frac{1}{2}$ " wrench remove the natural gas orifice (#25) and replace with propane orifice ( $\frac{3}{32}$ " ) (our part # 5021.31) (Fig. #16)
5. Fully open the primary air shutter.
6. Reinstall the manifold assembly

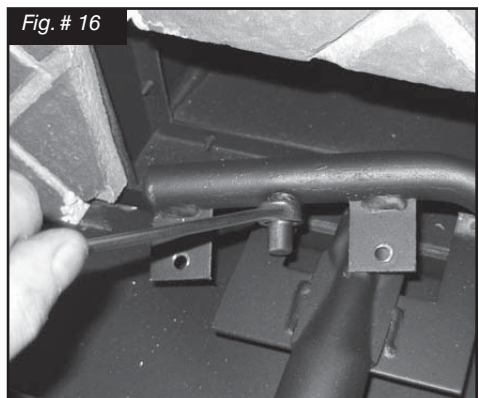
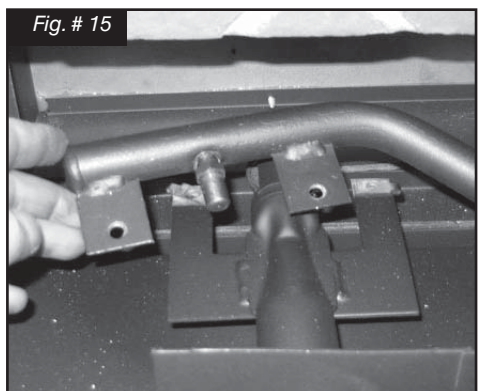
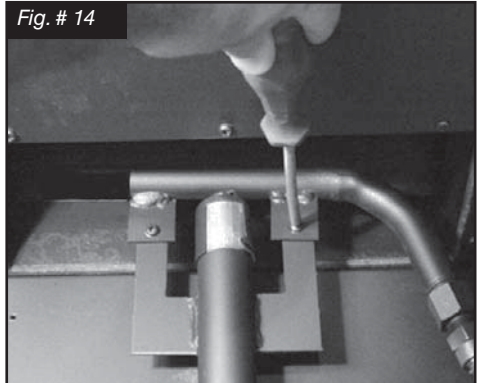
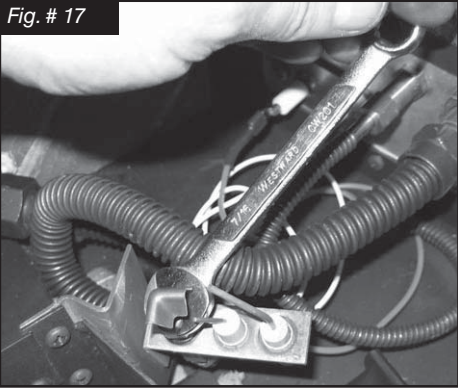
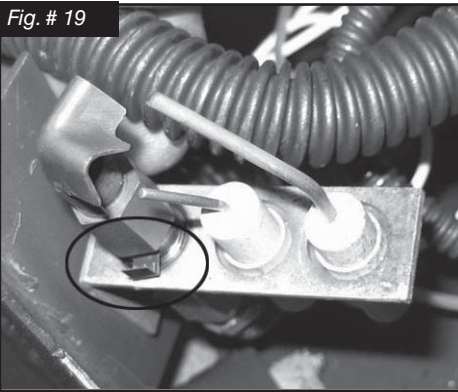

Fig. # 17



7. With a 7/16" wrench loosen the pilot head on the pilot assembly by a half-turn (Fig. #17)

Fig. # 19



8. Slide the pilot adjustment band over and ensure that the hole in the orifice band is showing. (Fig. #19 shows NG position, Fig. # 20 shows LP position)

Fig. #20

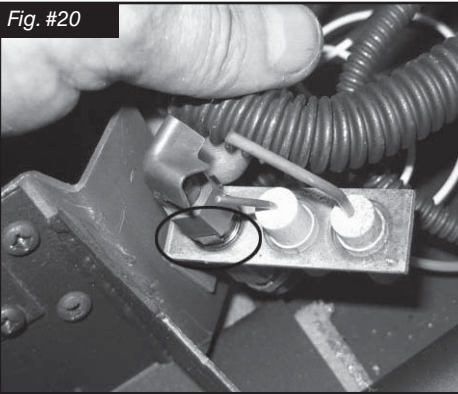
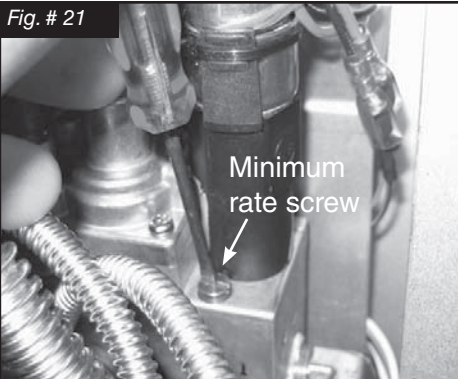
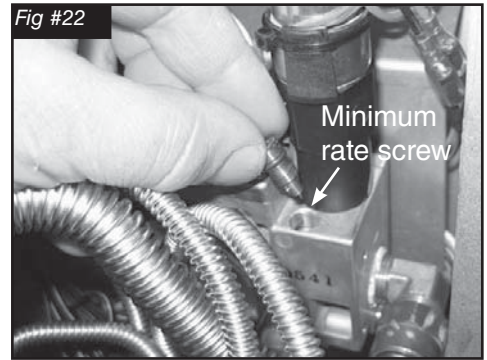

Fig. # 21



9. Remove the minimum rate screw located in the valve. (Fig. #21)

10. Replace the minimum rate screw with the one provided in the propane conversion kit supplied with this fireplace. Ensure that the screw is fully installed. (Fig. #22)



11. Pull off the rubber cap from the top of the pressure regulator. (Fig. #23)

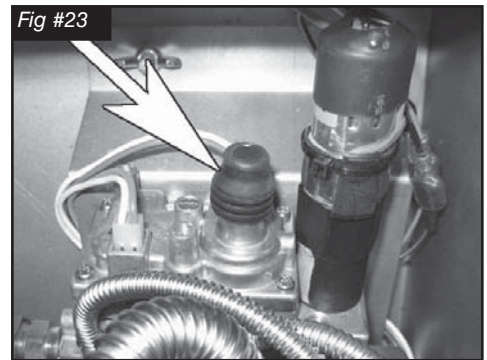

12. Press down on the center post and rotate 90°. The center post should stay down. (Fig. #24). Replace the rubber cap.

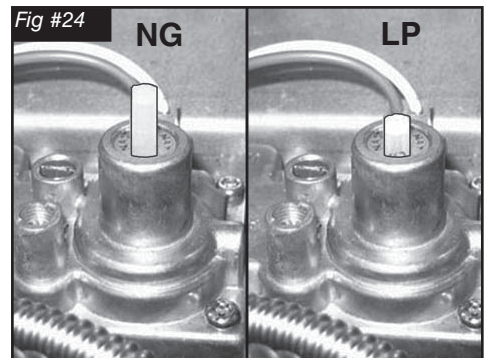

13. Fill in the date and the name of the person who performed the conversion in the white area on the conversion label. Peel off the protective backing and apply the conversion label directly over the gas specifications on the rating label.

14. Attach the access panel to the side of the firebox with the previously removed screws. (Fig. #25)

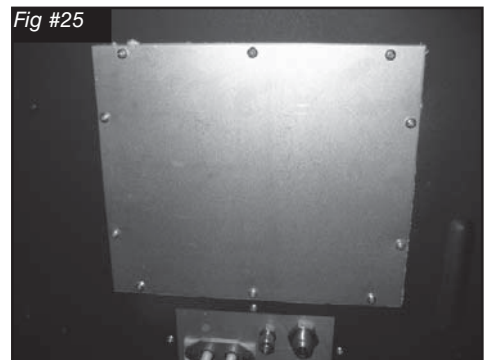

**Note:**  
Gasket must be installed with access panel.

# Gas Pressure Check

**Note:** To test the gas pressure, turn off the gas supply before removing the plug from the supply pressure test port or manifold pressure test port.

Verify gas pressures with the fireplace lit and on the highest setting.



1. Remove the plug from the manifold test port. The plug is located between the right side lintel and firebox side (bottom port). (Fig. # 26)

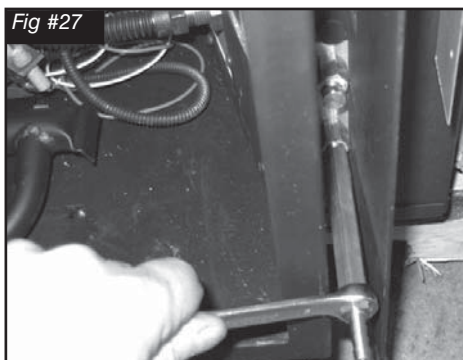

2. Thread the extension test fitting into the open test port. (Fig. #27)
3. Attach a pressure gauge onto the fitting.
4. When testing is complete remove the extension test fitting and replace the plug. Thread sealant will be required to ensure a gas-tight connection.

## Correct gas pressure requirement:

**Supply Pressure**  
(For purpose of input adjustment)

**Natural Gas**

**Propane**

**Minimum**  
**Maximum**

**5.0" WC**  
**13.9" WC**

**12.5" WC**  
**13.9" WC**

**Manifold Pressure**

**Maximum**  
**Minimum**

**3.8" WC**  
**2.1" WC**

**11.0w" WC**  
**5.5" WC**

# Burner Flame Adjustment

The air shutter on the burner tube controls the primary combustion air to the gas burner and is preset at the factory for natural gas fuel. Some adjustment may be necessary to obtain desired flame and to eliminate carbon deposits. Evaluate flame appearance after the fireplace has reached operating temperature. See Fig. #28 for proper flame pattern.

Open primary air shutter if the logs, glass, and firebox have carbon accumulation and / or the flames are long, dark and stringy. The shutter may also be opened to enhance the Ember Material glow and lessen the flame height.

**Caution: Burner area may be hot!**

Turn off the fireplace and allow the unit to cool before proceeding.

**Caution: Proper air shutter setting is a must.**

The flame should be just orange and "lazy". It should NEVER be set to create sooting on internal parts and glass.



**To Adjust:** (Fig. #29)

1. Open and remove window frame and set aside. See "Window Frame Removal" section found in the Installation and Operating Instructions manual.
2. Remove the log set and set aside.
3. Loosen the screw in the Primary Air Shutter.
4. Rotate the shutter to increase or decrease the amount of primary air.
5. Reassemble in reverse order.

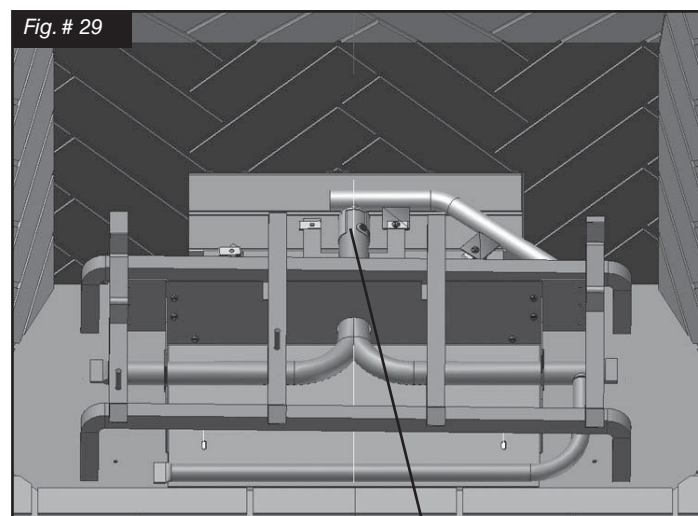

PRIMARY AIR SHUTTER

# Replacement Parts

(WHEN ORDERING, INCLUDE PART NUMBER WITH DESCRIPTION)

ITEM.....DESCRIPTION.....PART NO.

#1..... BURNER ASSEMBLY..... TC42.NG06.C

#2..... 7 PCS LOG SET ..... 5094.42161

#3..... ORIFICE, NATURAL GAS (#25)..... 5022.12

ITEM.....DESCRIPTION.....PART NO.

#4..... PILOT ASSEMBLY..... TCRP.5005025

#5..... MAIN SUPPLY TUBE (FLEX)..... 5019.223

#6..... PILOT TUBE (FLEX)..... 5019.225

\* #7..... PROPANE CONVERSION KIT ..... TC42.LPCEO1

\* NOT SHOWN

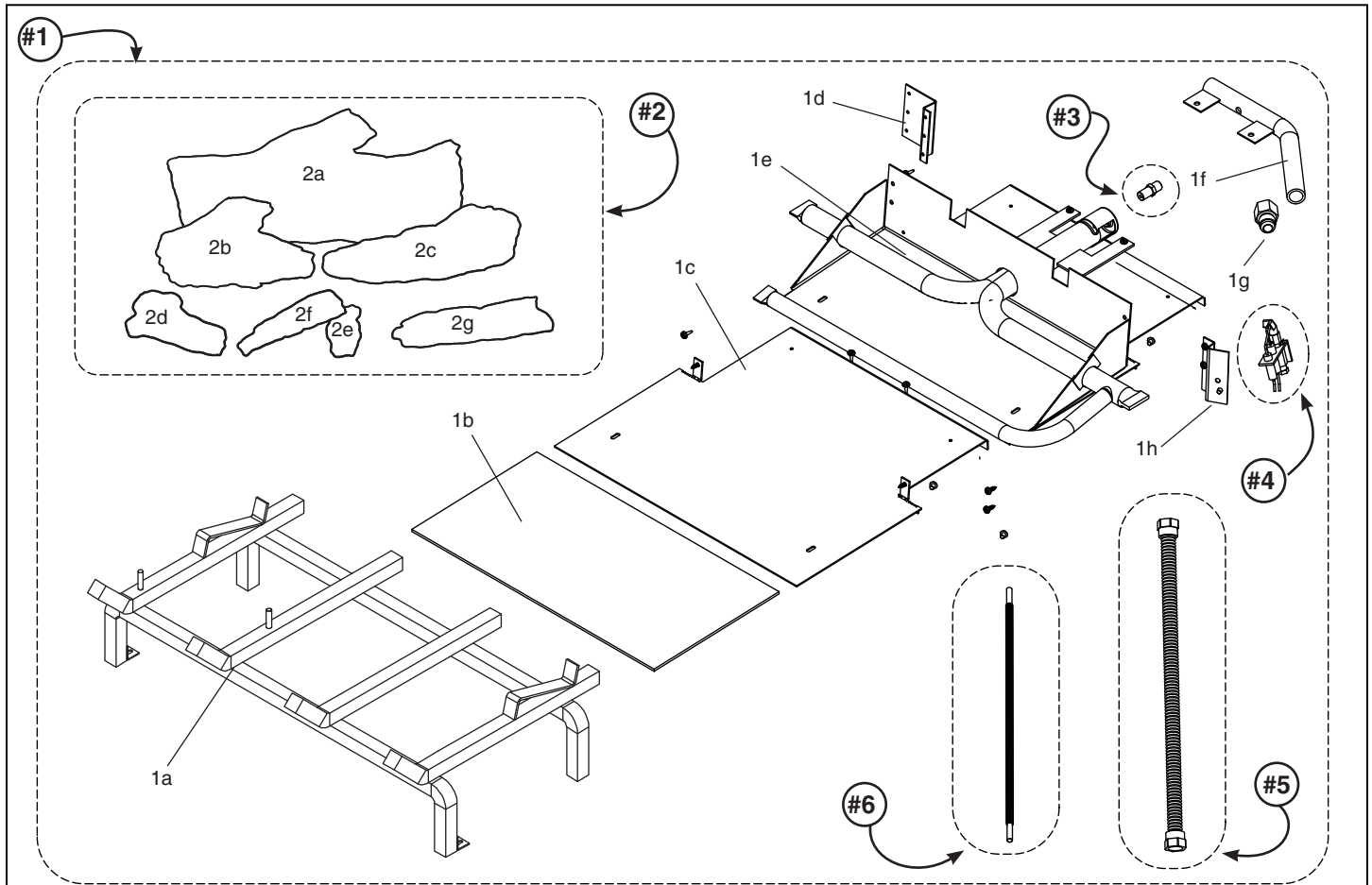

## KIT CONTENTS:

### #1.... BURNER ASSEMBLY

- 1a GRATE
- 1b BURNER INSULATION
- 1c BURNER TRAY SUPPORT SHIELD
- 1d PILOT SHIELD
- 1e TC42.NG01 BURNER WELD
- 1f MANIFOLD
- 1g 1/2 PIPE TO 1/2 TUBE CONNECTION
- 1h PILOT BRACKET
- 2a LOG #1
- 2b LOG #2
- 2c LOG #3
- 2d LOG #4
- 2e LOG #5
- 2f LOG #6
- 2g LOG #7

### 3 ORIFICE, NATURAL GAS

- 4 PILOT ASSEMBLY
- 5 MAIN SUPPLY TUBE
- 6 PILOT TUBE

### #2.... 7 PCS LOG SET

- EMBER MATERIAL (Not shown)
- 2a LOG #1
- 2b LOG #2
- 2c LOG #3
- 2d LOG #4
- 2e LOG #5
- 2f LOG #6
- 2g LOG #7

### #3.... ORIFICE, NATURAL GAS (#25)

### #4.... PILOT ASSEMBLY, CONVERTIBLE

### #5.... MAIN SUPPLY TUBE (FLEX)

### #6.... PILOT TUBE (FLEX)

### #7.... PROPANE CONVERSION KIT (Not shown)



TOWN & COUNTRY  
FIREPLACES™

**TECHNICAL SUPPORT: 1-888-715-2664**  
**[www.townandcountryfireplaces.net](http://www.townandcountryfireplaces.net)**  
**2975 Allenby Rd., Duncan, BC V9L 6V8**