

**INSTALLER:** Leave this manual with the appliance.  
**CONSUMER:** Retain this manual for future reference.

These instructions are supplementary to the Installation and Operating Instructions supplied with the fireplace and should be kept together. Refer to the Installation and Operating Instructions for proper gas supply, safety requirements and operating instructions



**TOWN & COUNTRY  
FIREPLACES™**

## **TC42 BLACK DIAMOND BURNER KIT INSTRUCTIONS**



**PART#  
TC42.NG03.C  
FOR TC42**



## Contents of Package

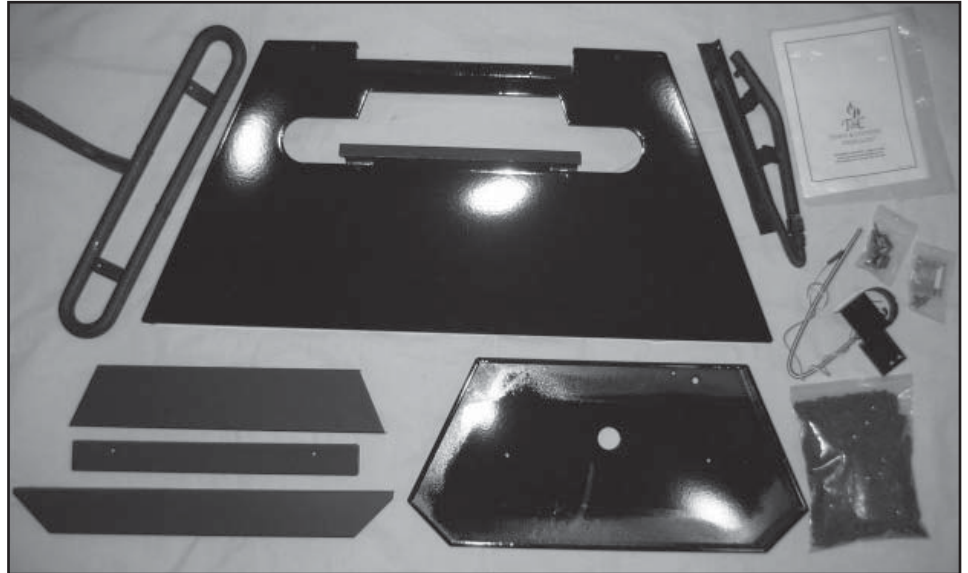

- BURNER
- BURNER TRAY ASSEMBLY
- TUMBLED GLASS
- BURNER SHIELD
- MANIFOLD ASSEMBLY (including supply tube)
- PILOT SHIELD (including pilot and pilot supply tube)
- HARDWARE PACKAGE
- MEDIA SPACER, rear
- MEDIA SPACER, front
- MEDIA SPACER, center

NOTE: MUST BE USED WITH PORCELAIN PANELS #TC42.PNLPBKB

# Burner Installation

A porcelain panel set must be used in conjunction with the installation of the burner assembly. See Installation and Operating Instructions manual for details.

Fig. # 1

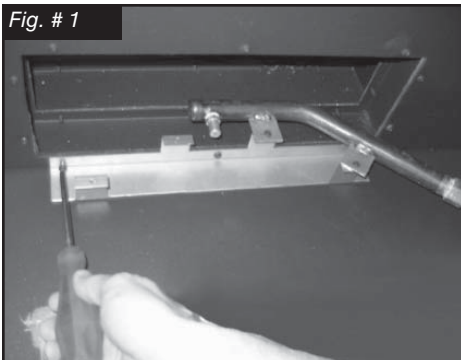

1. Remove the three lower screws from the air channel at the back of the firebox and attach the manifold assembly to the back of the firebox. (Fig. #1)

Fig. # 3

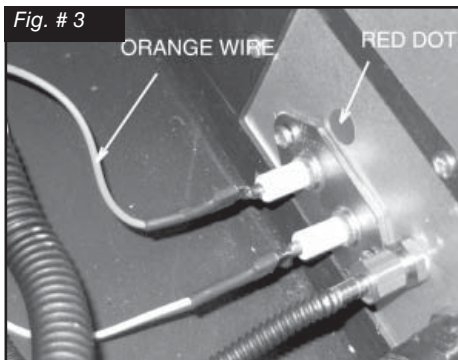

3. Attach spark electrode (ORANGE) and sensor leads to the electrical bulk head. (Fig. #3) (The spark electrode connection has a red dot above it)

Fig. # 2

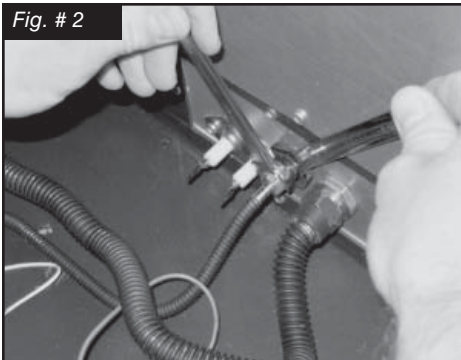

2. Connect flex lines from the manifold and pilot assemblies to the bulkhead in the firebox side. (Fig. #2) Ensure that the connection is gas tight.

Fig. # 4



4. Panel clips must be installed on the bottom of both side panels (notch facing inside). (Fig. #4) to ensure proper positioning of the burner shield. This must be done at the same time as installing the porcelain side panels.
5. Install rear panel of porcelain panel set. The base panel of the porcelain panel set is not used with the Black Diamond installation, and may be discarded.

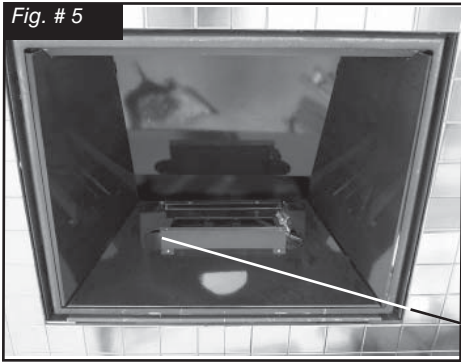

INSTALLING BURNER SHIELD

6. Install burner shield by tipping the shield into the firebox, catching the folded edges in the panel clips. (Fig. #5)



9. Attach pilot shield to burner tray with two screws. (Fig. #8)

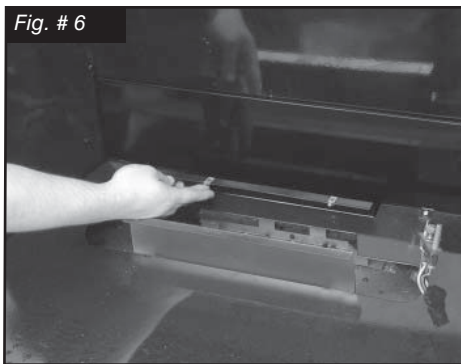

7. Position clip nuts, included in hardware package, onto burner shield. (Fig. #6)

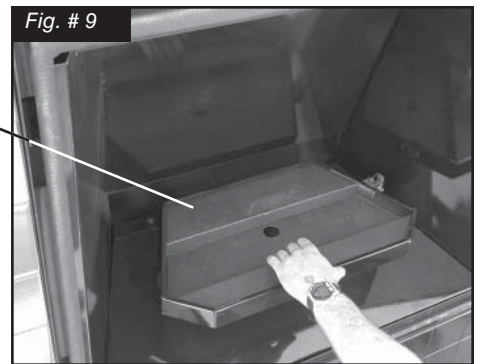

REAR MEDIA SPACER

10. Install front & rear media spacers. (Fig. #9 & 10)



8. Attach the burner tray to the burner shield using two screws at the back of the tray. (Fig. #7)

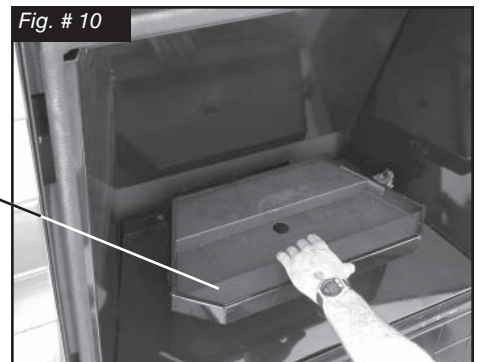

FRONT MEDIA SPACER

11. Set the burner air shutter to fully open for propane or fully closed for natural gas.

Fig. # 11



12. Install burner by tilting burner inlet through tray. Ensure that the orifice has entered the inlet tube. (Fig. #11 & 12)

Fig. # 14



14. Apply just enough glass media to cover the burner assembly. (Fig. #14)

**NOTE: Too much glass media over the burner will cause sooting with the use of propane gas.**

**Unit is designed specifically to use glass media part # 5012.01. Use of any other glass or material will void warranty.**

Fig. # 12



Fig. # 13

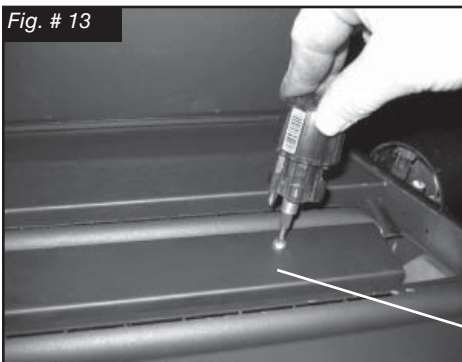

CENTRE MEDIA SPACER

13. Install the center media spacer and secure spacer to the tray with the two long screws provided. (Fig. #13)

# Propane Conversion

## WARNING

This conversion kit shall be installed by a qualified service agency in accordance with the manufacturer's instructions and all applicable codes and requirements of the authority having jurisdiction.

If the information in these instructions is not followed exactly, a fire, explosion or production of carbon monoxide may result causing property damage, personal injury or loss of life.

The qualified service agency is responsible for the proper installation of this kit.

The installation is not proper and complete until the operation of the converted appliance is checked as specified in the manufacturer's instructions supplied with the kit.

## CAUTION

The gas supply and electrical power shall be shut off before proceeding with the conversion.

If the unit is to be used on propane convert as follows using the components supplied with this fireplace:

Note: Factory supplied components must be used to ensure correct input. After conversion confirm proper manifold pressure.

1. Ensure the burner, pilot and gas supply are turned off, and the appliance has cooled.
2. With a 1/2" wrench remove the natural gas orifice (#25) and replace with propane orifice (3/32")(our part # 5021.31) (Fig. #15)
3. Fully open the primary air shutter.
4. Remove the pilot shield from the burner tray by removing two screws (Fig. #16)
5. With a 7/16" wrench loosen the pilot head on the pilot assembly by a half-turn (Fig. #17)

Fig. # 15

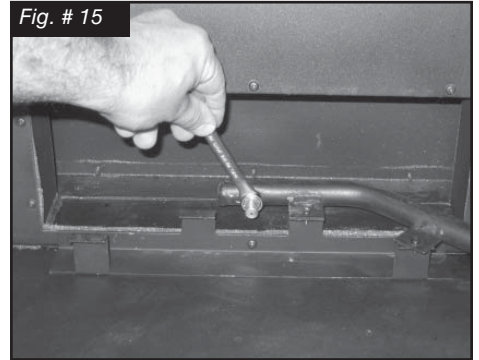

Fig. # 16



Fig. # 17

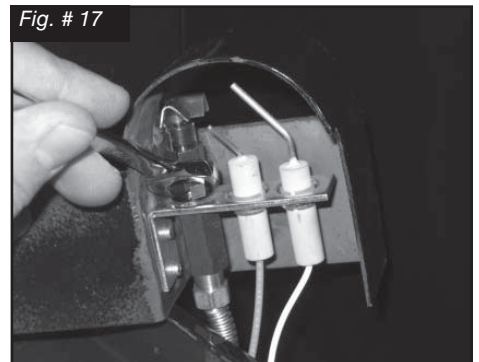
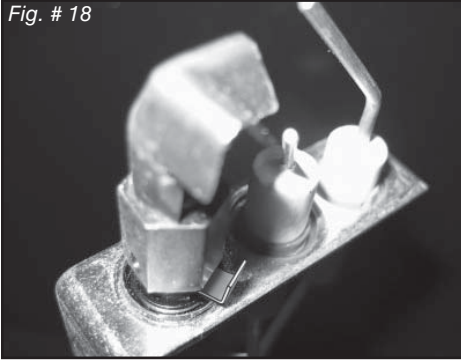

Fig. # 18



6. Slide the pilot adjustment band over and ensure that the hole in the orifice band is showing. (Fig. #18 shows NG position, Fig.#19 shows LP position)

Fig. # 19

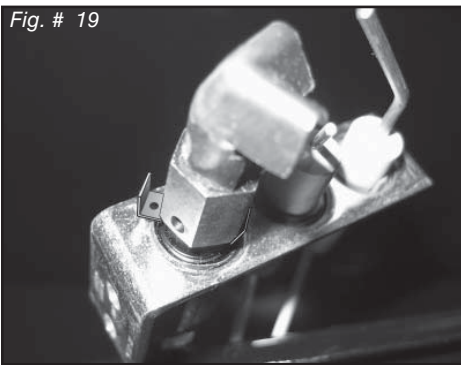
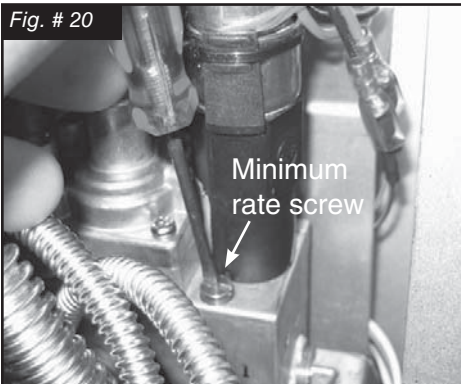

Fig. # 20



7. Remove the minimum rate screw located in the valve. (Fig. #20)

The minimum rate screw is sealed with an o-ring near the bottom of the screw. Use a thin bladed screwdriver to back the screw out to the limit of the threads.

A groove on the screw body will be visible just above the valve body. Insert a thin tool (knife blade or thin screwdriver blade) into the groove and gently pry the screw up.

It helps to rotate the screw while lifting on it.

11. Replace the minimum rate screw with the one provided in the propane conversion kit supplied with this fireplace. Ensure that the screw is fully installed. (Fig. #21)

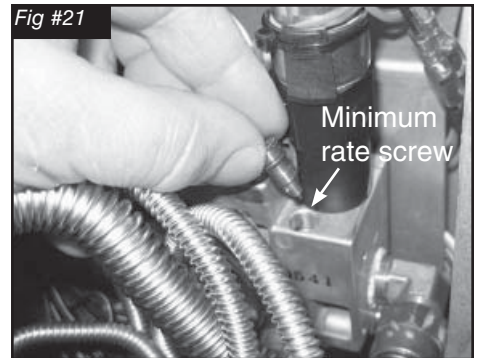

9. Pull off the rubber cap from the top of the pressure regulator. (Fig. #22)

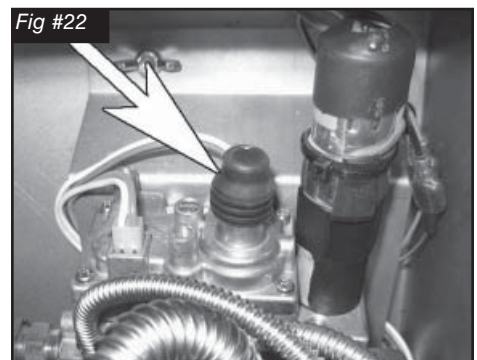

10. Press down on the center post and rotate 90°. The center post should stay down. (Fig. #23). Replace the rubber cap.

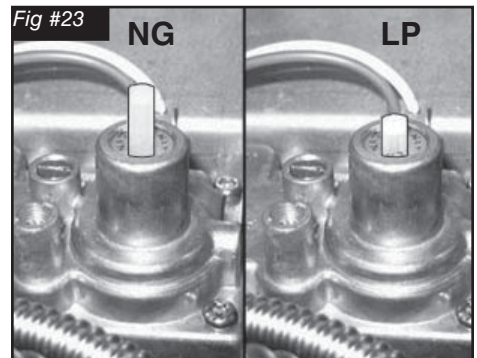

11. Fill in the date and the name of the person who performed the conversion in the white area on the conversion label. Peel off the protective backing and apply the conversion label directly over the gas specifications on the rating label.

12. Attach the access panel to the side of the firebox with the previously removed screws. (Fig. #24)

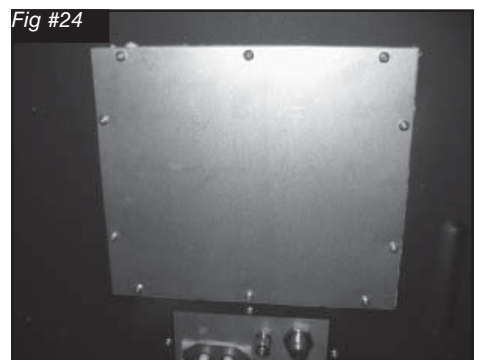

**Note:**  
**Gasket must be installed with access panel.**

# Gas Pressure Check

**Note:** To test the gas pressure, turn off the gas supply before removing the plug from the supply pressure test port or manifold pressure test port.

Verify gas pressures with the fireplace lit and on the highest setting.

Fig #25



1. Remove the plug from the pressure test port. The plug is located between the right side lintel and firebox side. (Fig. #25)

Fig #26

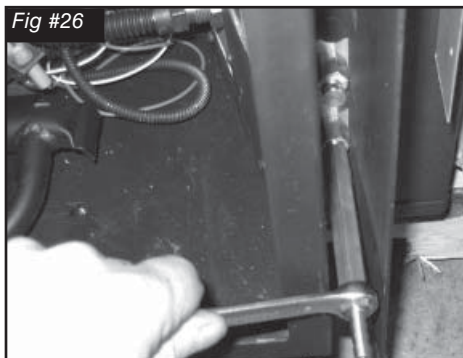

2. Thread the extension test fitting into the open test port. (Fig. #26)
3. Attach a pressure gauge onto the fitting.
4. When testing is complete remove the extension test fitting and replace the plug. Thread sealant will be required to ensure a gas tight connection.

## Correct gas pressure requirement:

**Supply Pressure**  
(For purpose of input adjustment)

**Natural Gas**

**Propane**

**Minimum**

**5.0" WC**

**12.5" WC**

**Maximum**

**13.9" WC**

**13.9" WC**

**Manifold Pressure**

**Maximum**

**3.8" WC**

**11" WC**

**Minimum**

**2.1" WC**

**5.5" WC**

## Burner Flame Adjustment

The air shutter on the burner inlet tube controls the primary combustion air to the gas burner and is preset closed at the factory for natural gas fuel. Some adjustment may be necessary to obtain desired flame and to eliminate carbon deposits. Evaluate flame appearance after the fireplace has reached operating temperature. See Fig. #27 for proper flame pattern.

Open primary air shutter if the glass, and firebox have carbon accumulation and/or the flames are long, dark and stringy. The shutter may also be opened to lessen the flame height.

### **Caution: Burner area may be hot!**

Turn off the fireplace and allow the unit to cool before proceeding.



The flame should be just orange and "lazy". It should NEVER be set to create sooting on internal parts and glass.

### **To Adjust:** (See Fig. # 28)

1. Open and remove window frame and set aside. See "Window Frame Removal" section found in the Installation and Operating Instructions manual.
2. Remove the lower rear panel and set aside.
3. Loosen the screw securing the primary air shutter.
4. Rotate the shutter to increase or decrease the amount of primary air.
5. Re tighten the primary air shutter.
6. Reinstall lower rear panel.

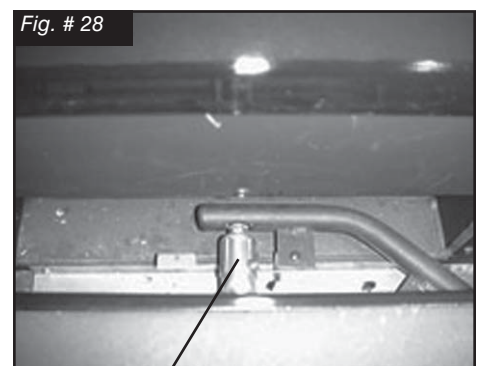

PRIMARY AIR SHUTTER

The flame should be just orange and "lazy". It should NEVER be set to create sooting on internal parts and glass.

# Replacement Parts

ITEM.....	DESCRIPTION.....	PART NO.
1.....	BURNER .....	TC42.5011832
2.....	ORIFICE, NG .....	5022.12
.....	ORIFICE, LP .....	5021.31
3.....	MANIFOLD STAND.....	
4.....	MANIFOLD.....	TC42.90881
5.....	DORMONT FITTING.....	5019.221
6.....	MEDIA SPACER, REAR .....	
7.....	PILOT SHIELD.....	TC36.9626PBK
8.....	MEDIA SPACER, CENTRE .....	
9.....	MEDIA SPACER, FRONT.....	

ITEM.....	DESCRIPTION .....	PART NO.
10.....	SHIELD LEG .....	
11.....	BURNER SHIELD .....	
12.....	TRAY SUPPORT .....	
13.....	BURNER TRAY.....	
14.....	PILOT ASSEMBLY, CONVERTIBLE ....	5005.025
15.....	1/4" FLEX TUBE (Pilot) .....	5019.225
16.....	1/2" FLEX TUBE (Manifold).....	5019.223
.....	HARDWARE PACKAGE .....	TC36.HK03
.....	TUMBLLED GLASS .....	5012.01

\*Not sold separately

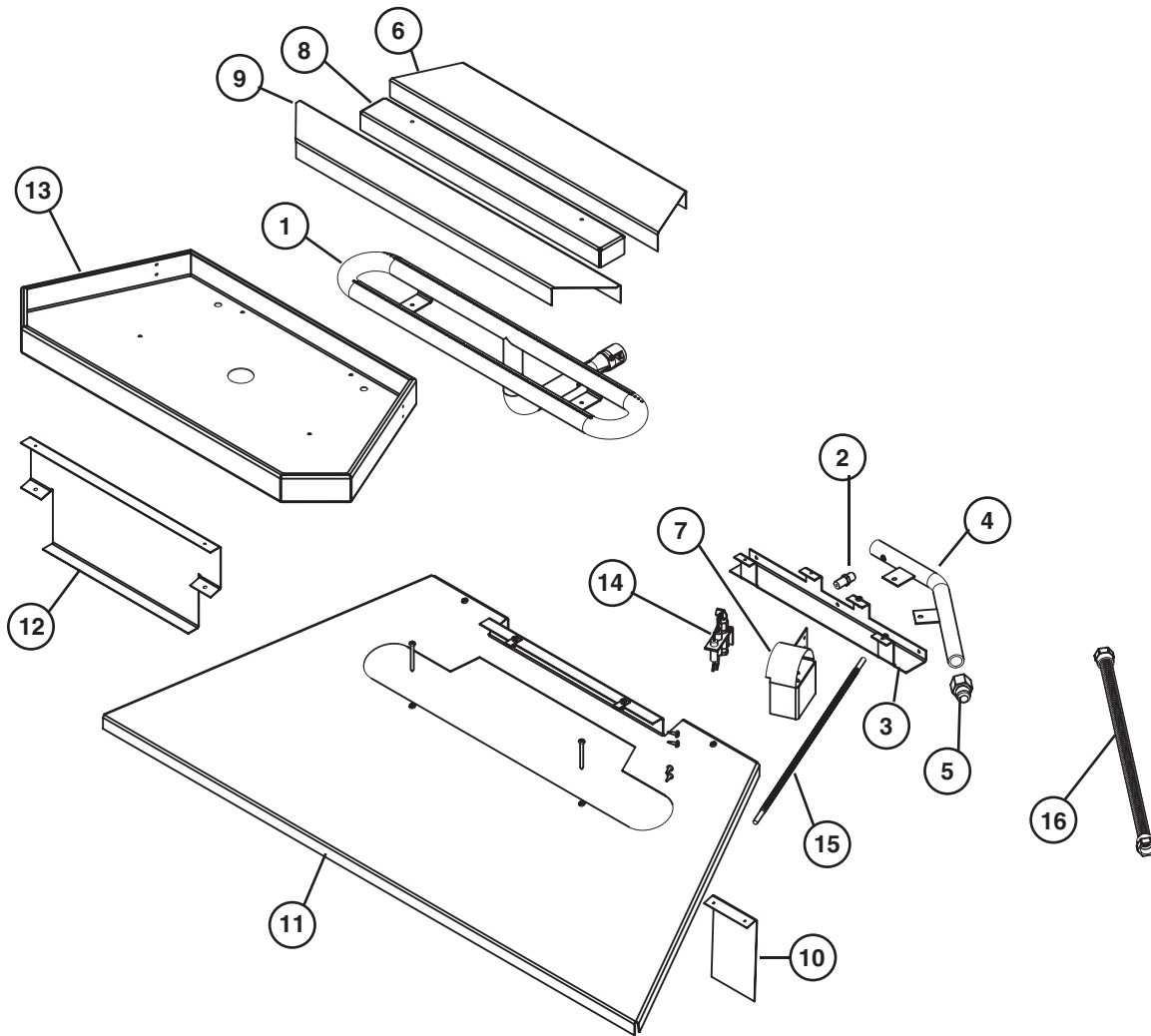



TOWN & COUNTRY  
FIREPLACES™

**TECHNICAL SUPPORT: 1-888-715-2664**  
**[www.townandcountryfireplaces.net](http://www.townandcountryfireplaces.net)**  
**2975 Allenby Rd., Duncan, BC V9L 6V8**