

**IMPORTANT:
THESE INSTRUCTIONS ARE TO REMAIN
WITH THE HOMEOWNER**

These instructions are supplementary to the Installation and Operating Instructions supplied with the fireplace and should be kept together. Refer to the Installation and Operating Instructions for proper gas supply, safety requirements and operating instructions.



**TOWN & COUNTRY
FIREPLACES™**

TC54 BLACK DIAMOND BURNER KIT INSTRUCTIONS



**PART# TC54.NG03.C
For TC54 Series C**



Contents of Package

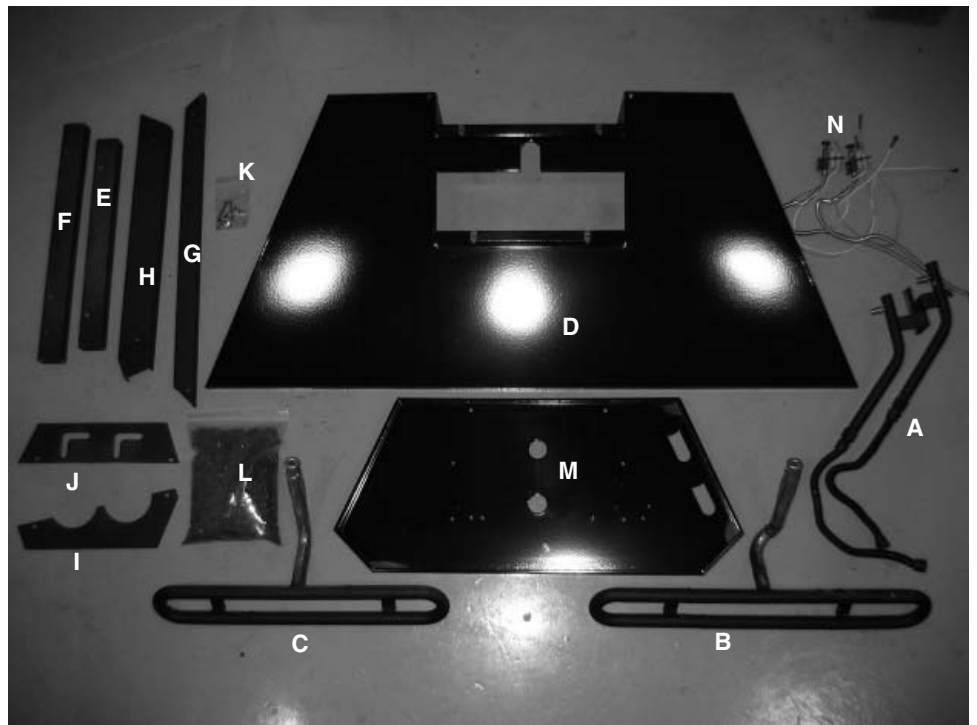

- A** MANIFOLD ASSEMBLY
(including supply tube)
- B** BURNER TUBE, FRONT
- C** BURNER TUBE, REAR
- D** BURNER SHIELD
- E** MEDIA SPACER, Rr Center
- F** MEDIA SPACER, Fr Center
- G** MEDIA SPACER, Front
- H** MEDIA SPACER, Rear
- I** MEDIA SPACER, Left
- J** MEDIA SPACER, Right
- K** HARDWARE PACKAGE
- L** 5 lbs. GLASS MEDIA
- M** BURNER TRAY
- N** PILOTS
- O** CONVERSION KIT (not shown)

Black Diamond Burner Installation

The panel set instructions must be used when installing this burner. Typically all panels except the right side should be installed prior to burner installation.

NOTE: Plug the 4 vacant holes in the bottom of the firebox with 1/2" screws, as they are not required to attach this style of burner.

1. Remove one screw from the center rear of the firebox and use it to attach the manifold assembly. (Fig. #1)

INSTALL MANIFOLD ASSEMBLY



NOTE:

If unit is to be converted to Propane, see Propane conversion instructions on page 7 before proceeding.

2. Place burner shield into unit, flexing right shield leg slightly to clear manifold. Make sure both pilots protrude through center hole. (Fig. #2)

INSTALL SHIELD



3. Cover the glossy surface of the burner shield to prevent surface damage while connecting pilots to the underside of the burner tray. **Attach the front pilot to the front of the burner tray first** then the rear pilot to the rear of the tray. (Fig. #3)

NOTE: Start screws with fingers first to prevent cross-threading.

ATTACH PILOTS



4. Place front media spacer to the front of the tray. (Fig. #4)

INSTALL FRONT MEDIA SPACER

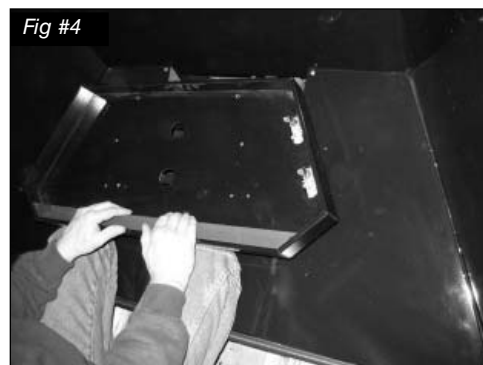



INSTALLING FRONT BURNER

5. Install front burner tube by tilting it into front tray hole until almost fully seated. (Fig. #5)

Set the air shutter to fully open for Propane or fully closed for Natural gas.

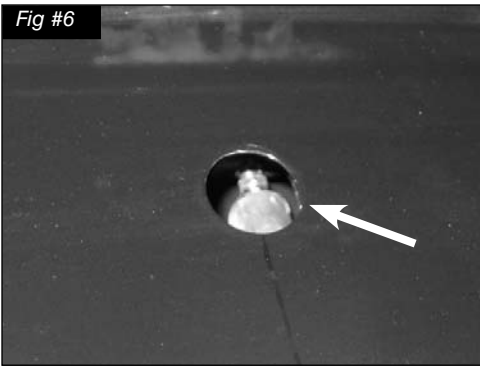

BURNER TUBE PLACEMENT

6. Guide tray and burner tube back until the burner tube engages the forward orifice. This can be seen through the rear burner hole. (Fig. #6)

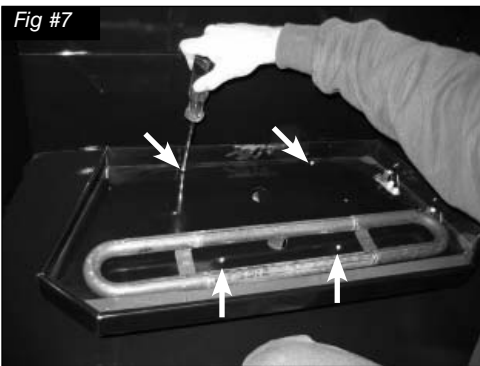

BURNER TRAY ATTACHMENT

7. Attach burner tray to shield with four screws. (Fig. #7)

8. The rear media spacer is now installed.
(Fig. #8)

REAR MEDIA SPACER



9. Install rear burner by tilting the inlet through the rear hole in the tray. Engage the inlet with the rear orifice. This can be seen from the back of the tray.
(Fig. #9)

Set the air shutter to fully open for Propane or fully closed for Natural gas.

INSTALL REAR BURNER



10. Install center media spacers and screw down through burner and tray with 1 1/2" screws. (Fig#10).
Three holes must line up to set each screw.

MEDIA SPACER
INSTALLATION



Fig #11

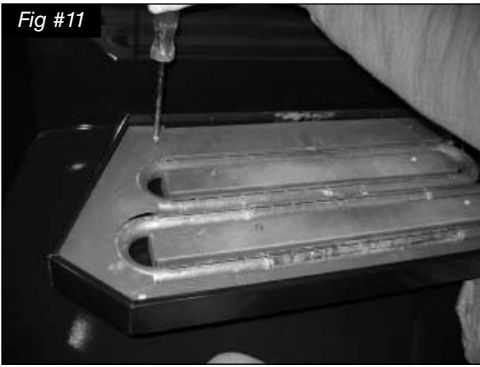

LEFT MEDIA SPACER

- 11. Install the left media spacer and secure to front and rear media spacers with two screws. (Fig. #11)

Fig #12



RIGHT MEDIA SPACER

- 12. Install right media spacer and secure to front and rear media spacers with two screws. (Fig. #12)

- 13. Apply just enough glass media to cover the burner assembly. (Fig #13 & 14)
Use caution not to get any glass media into the pilot slots.

NOTE: Too much tumbled glass over the burner will cause sooting with the use of propane gas.

Fig #13



GLASS MEDIA PLACEMENT

FINISHED INSTALLATION OF GLASS MEDIA

Fig #14



Propane Conversion

WARNING

This conversion kit shall be installed by a qualified service agency in accordance with the manufacturer's instructions and all applicable codes and requirements of the authority having jurisdiction.

If the information in these instructions is not followed exactly, a fire, explosion or production of carbon monoxide may result causing property damage, personal injury or loss of life.

The qualified service agency is responsible for the proper installation of this kit. The installation is not proper and complete until the operation of the converted appliance is checked as specified in the manufacturer's instructions supplied with the kit.

CAUTION

The gas supply and electrical power must be shut off before proceeding with the conversion.

If the unit is to be used on propane, convert as follows using the components supplied with this fireplace:

Note:

Factory supplied components must be used to ensure correct input. After conversion confirm proper manifold pressure.

1. Ensure the burner, pilot and gas supply are turned off, and the appliance has cooled.
2. Using a 1/2" wrench, undo both natural gas burner orifices (marked #28). (Fig. #15)
3. Apply a small amount of pipe joint compound to the threads of the propane burner orifice (marked #43) to ensure a good seal, before screwing it into the fitting.
4. Open primary air shutters fully.
5. With a 7/16" wrench loosen the pilot head on the pilot assembly (Fig. #16)
6. Slide the pilot adjustment band over and ensure that the hole in the orifice band is showing. (Fig. #17 indicates NG position, Fig. #18 indicates LP position)

Repeat steps 5 and 6 for other pilot.

Fig #15

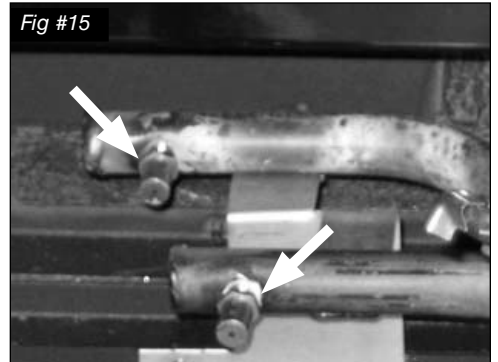

Fig #16

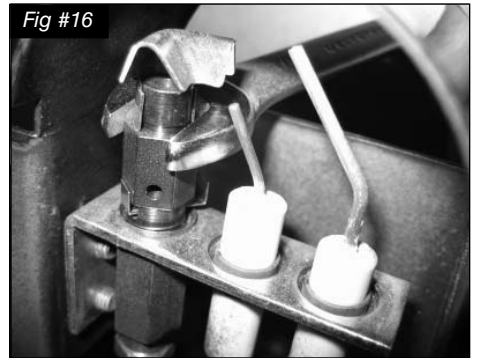

Fig #17



Fig #18



Fig #19



7. Remove access panel, 10 screws, and set aside (Fig. #23)
8. Remove the minimum rate screw located in the valve. (Fig. #19)

The minimum rate screw is sealed with an o-ring. Use a thin bladed screwdriver to back the screw out to the limit of the threads.

A groove on the screw body will be visible just above the valve body. Insert a thin tool (knife blade or thin screwdriver blade) into the groove and gently pry the screw up.

It helps to rotate the screw while lifting on it.

Fig #20



9. Replace the minimum rate screw with the one provided in the propane conversion kit supplied with this burner. Ensure that the screw is fully installed. (Fig. #20)

Fig #21



10. Pull off the rubber cap from the top of the pressure regulator. (Fig. #21)

Caution:

The center post must be up for natural gas and down for propane for the appliance to operate correctly.

11. Press down on the center post and rotate 90°. The center post should stay down. (Fig. #22). Replace the rubber cap.

Repeat steps 8 through 11 for other valve.

Fig #22

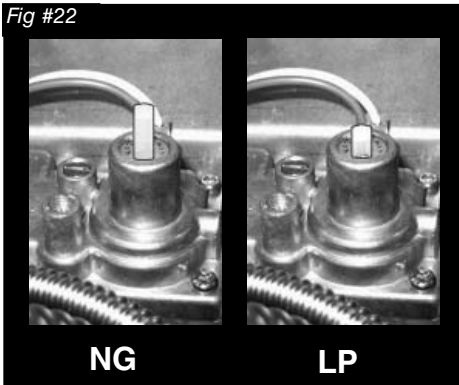

12. Fill in the date and the name of the person who performed the conversion in the white area on the conversion label. Peel off the protective backing and apply the conversion label directly over the gas specifications on the rating label.

13. Attach the access panel to the side of the firebox with the previously removed screws. (Fig. #23)

Note: Gasket must be installed with access panel.

Fig #23

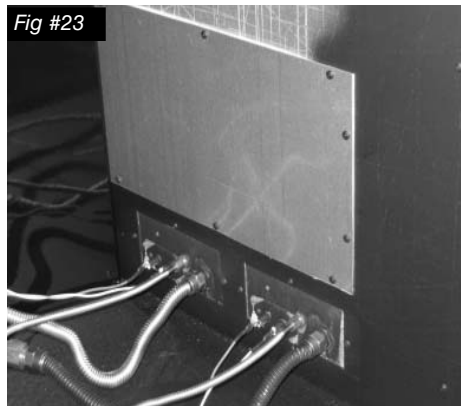

Gas Pressure Check

Note: To test the gas pressure, turn off the gas supply before removing the plug from the supply pressure test port or manifold pressure test port.

Verify gas pressures with the fireplace lit and on the highest setting.



1. Remove the plug from the pressure test port using a 7/16" socket and extension. The plug is located between the right side lintel and firebox side. (Fig. #24)

Fig #25a

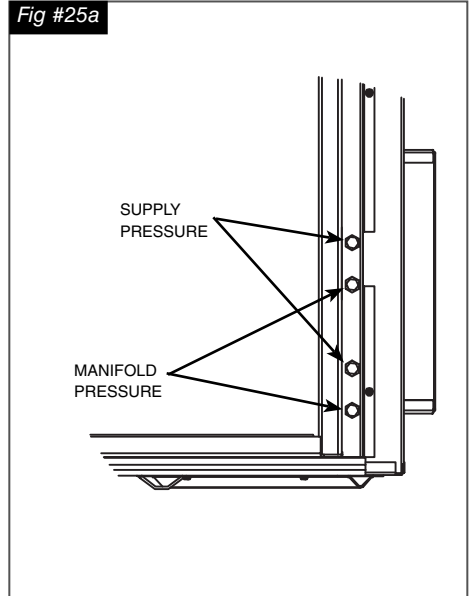

2. Thread the extension test fitting into the open test port. (Fig. #25)
3. Attach a pressure gauge onto the fitting.
4. When testing is complete remove the extension test fitting and replace the plug. Thread sealant will be required to ensure a gas tight connection.

Correct gas pressure requirement:

Supply Pressure	Natural Gas	Propane
Min. Pressure (For purpose of input adjustment)	5.0" WC	12.5" WC
Max. Pressure	13.9" WC	13.9" WC
Manifold Pressure		
Maximum	3.4" WC	11" WC
Minimum	1.8" WC	5.5" WC

Burner Flame Adjustment

The air shutter on the burner tube controls the primary combustion air to the gas burner. The shutter should be set to fully closed for natural gas or fully open for propane.

The flame should be just orange and “lazy”.

It should **NEVER** be set to create sooting on internal parts and window glass.

Fig #26



TC54 Black Diamond Replacement Parts

(WHEN ORDERING, INCLUDE PART NUMBER WITH DESCRIPTION)

ITEM	DESCRIPTION	PART NO.
#1	TC54 BLACK DIAMOND BURNER KIT	TC54.NG03.C
#2a	BURNER TUBE	TC54. 50118305
#2b	BURNER TUBE	TC42. 5011832.A
#3	PILOT ASSEMBLY, CONVERTIBLE (2 Required)	TCCV.5005025B
#4	ORIFICE, NG (#28) (2 Required)	5021.14
* #5	MANIFOLD ASSEMBLY	TC54.9654
* #6	GLASS MEDIA	TCCV.501201
* #7	PROPANE CONVERSION KIT	TC54.LPCE01

* NOT SHOWN

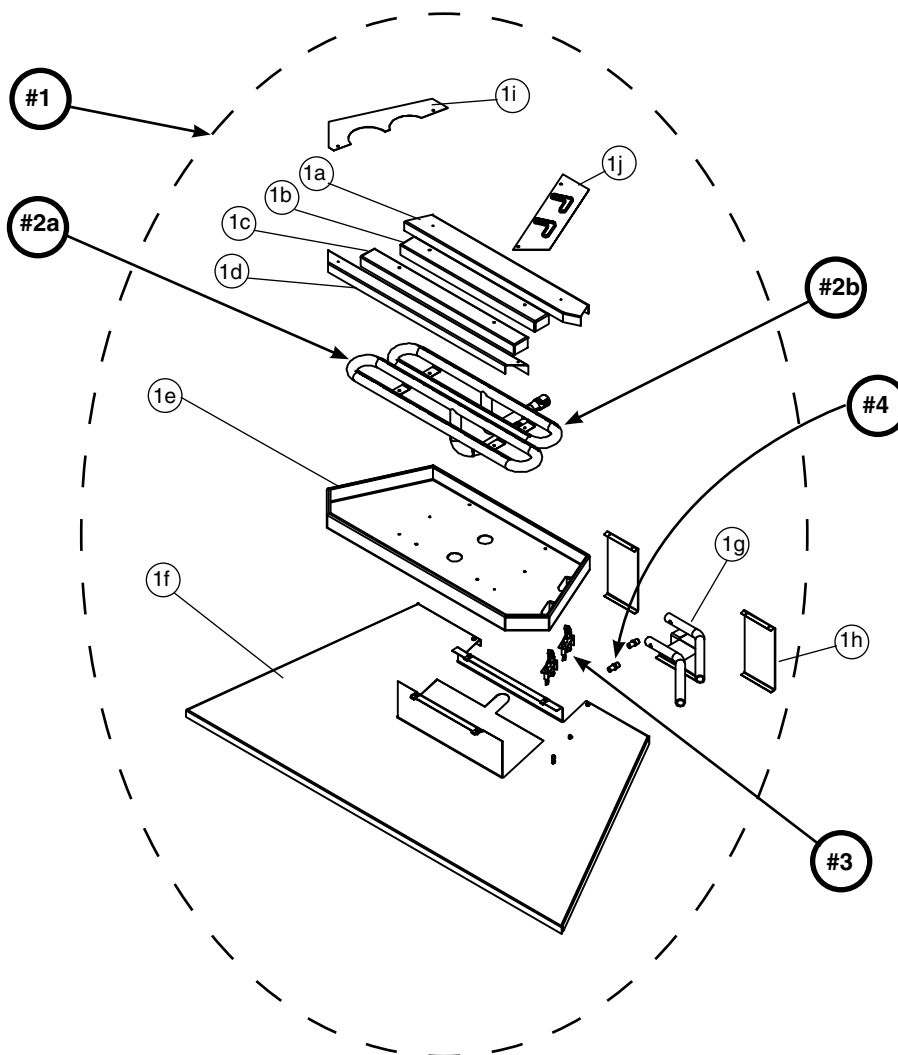

KIT CONTENTS:

- #1.....TC54 BLACK DIAMOND BURNER KIT
 - 1a MEDIA SPACER, REAR
 - 1b MEDIA SPACER, RR CENTER
 - 1c MEDIA SPACER, FR CENTER
 - 1d MEDIA SPACER, FRONT
 - 1e BURNER TRAY
 - 1f BURNER SHIELD
 - 1g MANIFOLD ASSEMBLY
 - 1h SHIELD LEG
 - 1i MEDIA SPACER, LEFT
 - 1j MEDIA SPACER, RIGHT
 - 2a BURNER TUBE, FRONT
 - 2b BURNER TUBE, REAR
 - 3 PILOT ASSEMBLY, CONVERTIBLE
 - 4 ORIFICE
 - 5 PILOT SUPPLY TUBE...(Not shown)
 - 6 MANIFOLD SUPPLY TUBE
...(Not shown)
 - 7 GLASS MEDIA...(Not shown)
 - 8 PROPANE CONVERSION KIT
...(Not shown)
-
- #2a...BURNER TUBE, FRONT
 - #2b ..BURNER TUBE, REAR
 - #3.....PILOT ASSEMBLY, CONVERTIBLE
 - #4.....ORIFICE, NG (#28)
 - #5 MANIFOLD ASSEMBLY...(Not shown)
 - #6.....GLASS MEDIA...(Not shown)
 - #7.....PROPANE CONVERSION KIT
...(Not Shown)



TOWN & COUNTRY
FIREPLACES™

Technical support: 1-877-715-2664
Web site: www.townandcountryfireplaces.net
2975 Allenby Rd., Duncan, BC V9L 6V8