

**IMPORTANT:
THESE INSTRUCTIONS ARE TO REMAIN
WITH THE HOMEOWNER**

These instructions are supplementary to the Installation and Operating Instructions supplied with the fireplace and should be kept together. Refer to the Installation and Operating Instructions for proper gas supply, safety requirements and operating instructions.



**TOWN & COUNTRY
FIREPLACES™**

TC54 TRANQUILITY BURNER KIT INSTRUCTIONS



**PART# TC54.NG04.C
For TC54 Series C**



Contents of Package

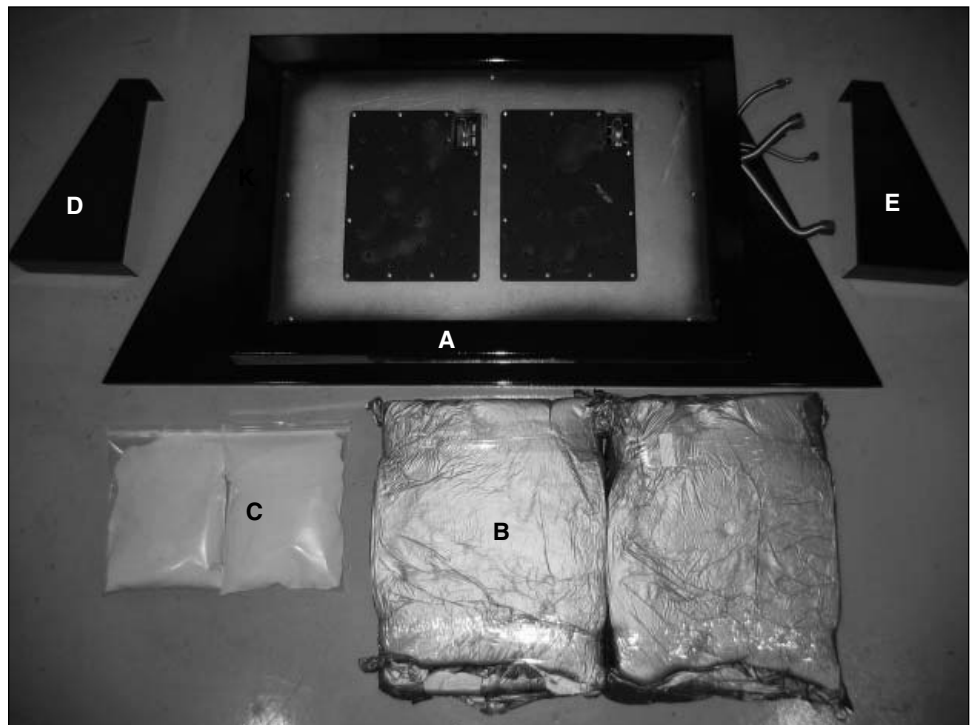

- A** BURNER ASSEMBLY
- B** PEBBLE ASSEMBLY
- C** 7lbs SAND
- D** LINE COVER, LEFT
- E** LINE COVER, RIGHT
- F** PKG. TAPERED PLUGS (not shown)

Black Diamond Burner Installation

A panel set must be used in conjunction with the installation of the burner assembly. See Installation and Operating Instructions manual for details.

* Typically all panels except the right side should be installed prior to burner installation.

NOTE: Due to the size of this unit it is highly recommended that two persons be available during installation.

NOTE: Plug the 4 vacant holes in the bottom of the firebox with 1/2" screws, as they are not required to attach this style of burner.

1. Position line covers on the base shield under the burner tray, one on each side. (Fig. #1)

LINE COVER PLACEMENT

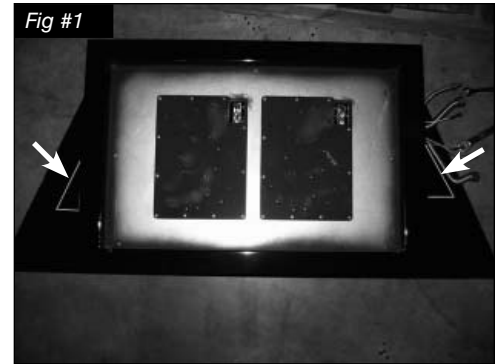

NOTE:

If unit is to be converted to Propane, see Propane conversion instructions on page 6 before proceeding.

2. Set the burner assembly into the firebox as shown to ease connection setup and right panel installation. Connect all wires and fuel lines ensuring a gas tight connection. (Fig. #2)

INITIAL BURNER PLACEMENT



NOTE: Pilot and manifold plumbing and wires are grouped and tied at the factory to ensure proper connection. Nylon zip ties must be removed after connections have been made, and prior to ignition.

3. Install right side panel as per panel installation instructions and finalize setting burner assembly into the unit. (Fig. #3)

BURNER INSTALLED



4. Slide the line covers out from under the burner tray and slip the tab into the slot in the assembly base. (Fig. #4)

INSTALL LINE COVERS





PLUGGING PORTS
WITH TAPER PLUGS

5. Place tapered plugs into all burner ports to prevent sand from entering the burners. (Fig. #5)

CAUTION: Before pouring sand ensure all connections and adjustments are made. Removing sand is very difficult.



SAND PLACEMENT

6. Pour sand evenly over tray and burners using the entire contents. Use caution not to let sand enter pilot locations. (Fig. #6)



SAND FINISHING

7. Brush the sand smooth and gently blow excess sand from around burner ports before removing the tapered plugs. (Fig. #7)

8. Remove tapered plugs. The pebble assemblies may now be installed.
Lift the assembly carefully by the bottom and place on tray aligning with locator pins. The hollowed rock on the assembly covers the pilot. (Fig. #8)

INSTALL PEBBLE ASSEMBLY



9. Place four trim rocks, approx. 2" dia., in spaces between the pebble assemblies to fill the gaps. Do not place rocks on top of the assemblies. (Fig. #9 and #10)

INSTALL TRIM ROCKS



10. Place the remaining four trim rocks at desired locations around the pebble assemblies. Do not place rocks on top of the assemblies. (Fig#10).

INSTALL TRIM ROCKS

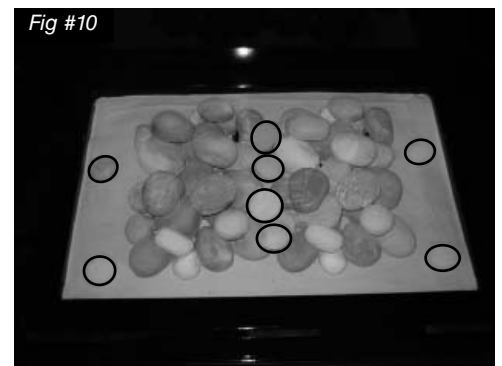

Propane Conversion

WARNING

This conversion kit shall be installed by a qualified service agency in accordance with the manufacturer's instructions and all applicable codes and requirements of the authority having jurisdiction.

If the information in these instructions is not followed exactly, a fire, explosion or production of carbon monoxide may result causing property damage, personal injury or loss of life.

The qualified service agency is responsible for the proper installation of this kit. The installation is not proper and complete until the operation of the converted appliance is checked as specified in the manufacturer's instructions supplied with the kit.

If the unit is to be used on propane, convert as follows using the components supplied with this fireplace:

Note:

Factory supplied components must be used to ensure correct input. After conversion confirm proper manifold pressure.

1. Ensure the burner, pilot and gas supply are turned off, and the appliance has cooled.
2. Remove three screws holding down the burner tray and lift off the tray sliding slightly forward to disengage from both orifices. (Fig. #11)
3. Using a 1/2" wrench, remove both natural gas burner orifices (marked #28). (Fig. #12)
4. Apply a small amount of pipe joint compound to the threads of the propane burner orifice (marked #43) to ensure a good seal, before screwing it into the fitting.

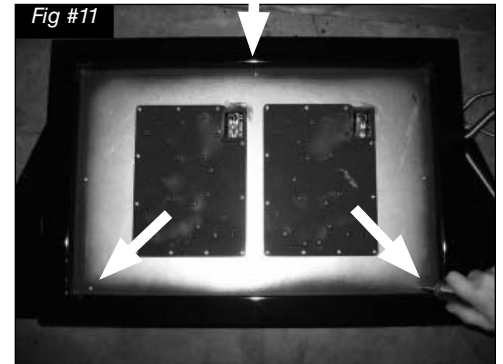

FRONT

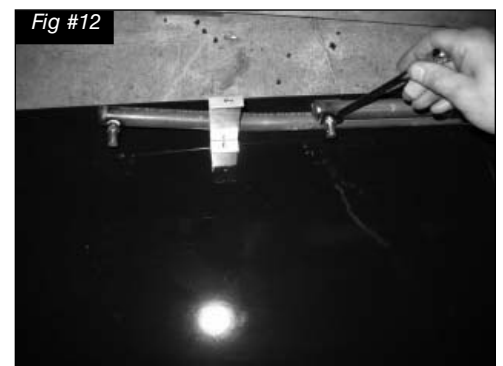

Fig #12

5. Open primary air shutters fully. Remove the pilots from the burners. (Fig. #13)

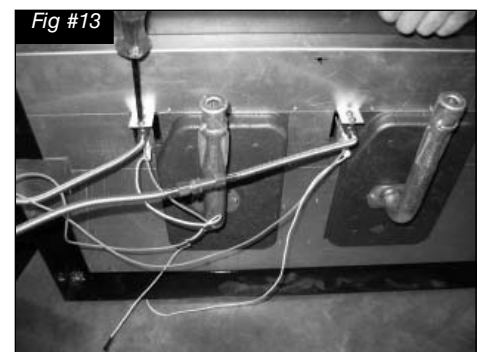
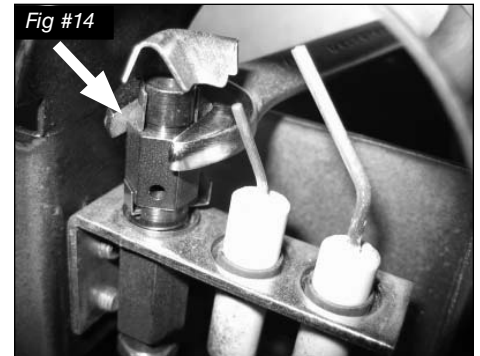

Fig #13

6. With a 7/16" wrench loosen the pilot head on the pilot assembly. (Fig. #14)
Hold the base of the pilot assembly secure with a wrench.



7. Slide the pilot adjustment band over and ensure that the hole in the orifice band is showing. (Fig. #15 indicates NG position, Fig. #16 indicates LP position)

Retighten the pilot head.

Replace the pilots and burner tray. Ensure the burner inlets engage both burner orifices.

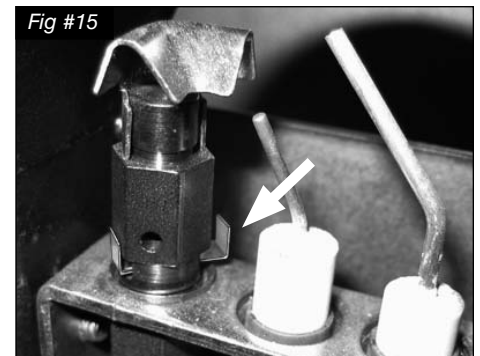
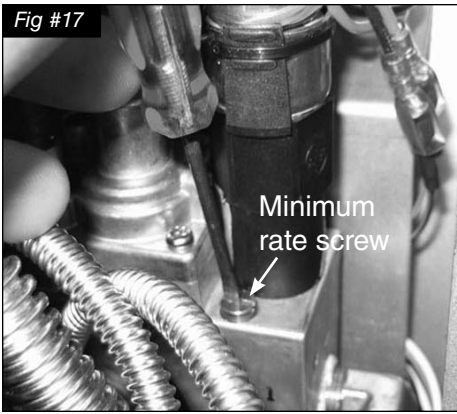

Fig #17



8. Remove access panel, 10 screws, and set aside. (Fig. #21)
9. Remove the minimum rate screw located in the valve. (Fig. #17)

The minimum rate screw is sealed with an o-ring. Use a thin bladed screwdriver to back the screw out to the limit of the threads.

A groove on the screw body will be visible just above the valve body. Insert a thin tool (knife blade or thin screwdriver blade) into the groove and gently pry the screw up.

It helps to rotate the screw while lifting on it.

Fig #18

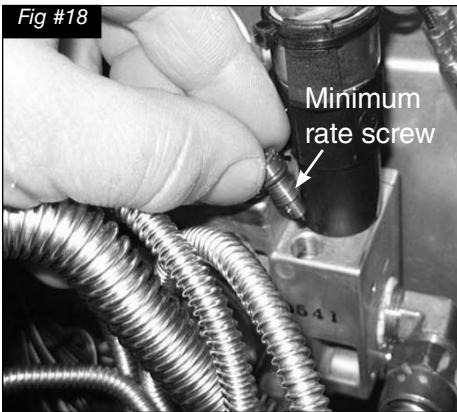

10. Replace the minimum rate screw with the one provided in the propane conversion kit supplied with this burner. Ensure that the screw is fully installed. (Fig. #18)

Fig #19



11. Pull off the rubber cap from the top of the pressure regulator. (Fig. #19)

Caution:

The center post must be up for natural gas and down for propane for the appliance to operate correctly.

12. Press down on the center post and rotate 90°. The center post should stay down. (Fig. #20). Replace the rubber cap.

Repeat steps 8 through 11 for other valve.

Fig #20

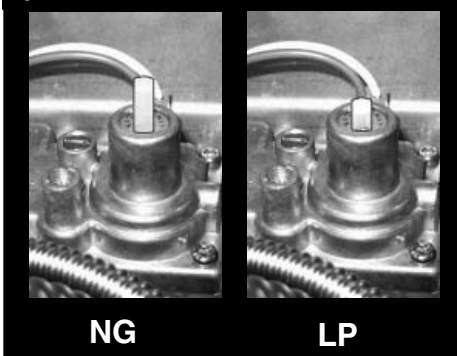

13. Fill in the date and the name of the person who performed the conversion in the white area on the conversion label. Peel off the protective backing and apply the conversion label directly over the gas specifications on the rating label.

14. Attach the access panel to the side of the firebox with the previously removed screws. (Fig. #21)

Note: Gasket must be installed with access panel.

Fig #21

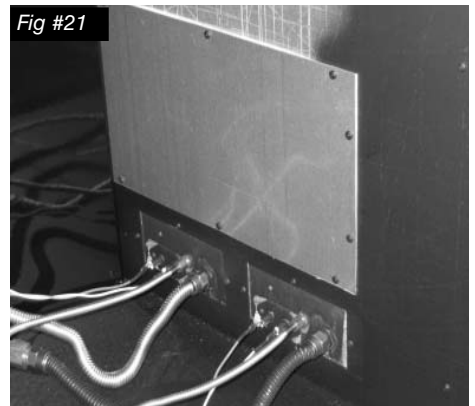

Gas Pressure Check

Note: To test the gas pressure, turn off the gas supply before removing the plug from the supply pressure test port or manifold pressure test port.

Verify gas pressures with the fireplace lit and on the highest setting.



1. Remove the plug from the pressure test port using a 7/16" socket and extension. The plug is located between the right side lintel and firebox side. (Fig. #22)

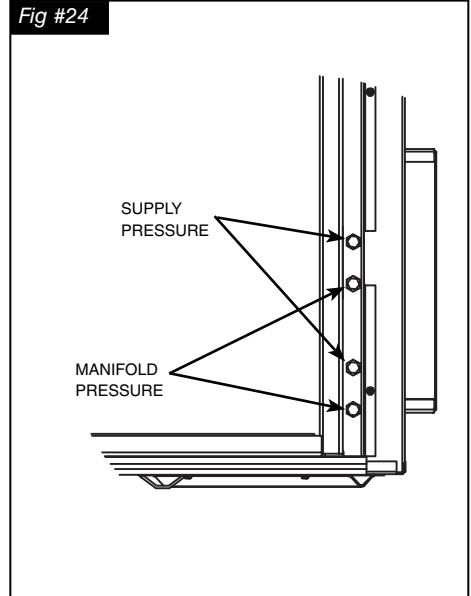

2. Thread the extension test fitting into the open test port. (Fig. #23)
3. Attach a pressure gauge onto the fitting.
4. When testing is complete remove the extension test fitting and replace the plug. Thread sealant will be required to ensure a gas tight connection.

Correct gas pressure requirement:

| Supply Pressure | Natural Gas | Propane |
|---|-----------------|-----------------|
| Min. Pressure (For purpose of input adjustment) | 5.0" WC | 12.5" WC |
| Max. Pressure | 13.9" WC | 13.9" WC |
| Manifold Pressure | | |
| Maximum | 3.4" WC | 11" WC |
| Minimum | 1.8" WC | 5.5" WC |

Burner Flame Adjustment

The air shutter on the burner tube controls the primary combustion air to the gas burner. The shutter should be set to fully closed for natural gas or fully open for propane.

The flame should be just orange and “lazy”.

It should **NEVER** be set to create sooting on internal parts and window glass.

Fig #25



TC54 Tranquility Burner Replacement Parts

(WHEN ORDERING, INCLUDE PART NUMBER WITH DESCRIPTION)

| ITEM | DESCRIPTION | PART NO. |
|------------|--|---------------|
| #1..... | TC54 TRANQUILITY BURNER KIT | TC54.NG04.C |
| #2..... | BURNER..... | TCRP.50118399 |
| #3..... | PILOT ASSEMBLY, CONVERTIBLE (2 Required) | TCCV.5005025B |
| #4..... | ORIFICE, NG (#28) (2 Required)..... | 5021.14 |
| * #5..... | MANIFOLD SUPPLY TUBE..... | 5019.223 |
| * #6..... | PEBBLE ASSEMBLY | TC54.9499 |
| * #7..... | PROPANE CONVERSION KIT..... | TC54.LPCE01 |
| * #8..... | 7lbs. SAND (2 Required)..... | TC42.SAND34 |

* NOT SHOWN

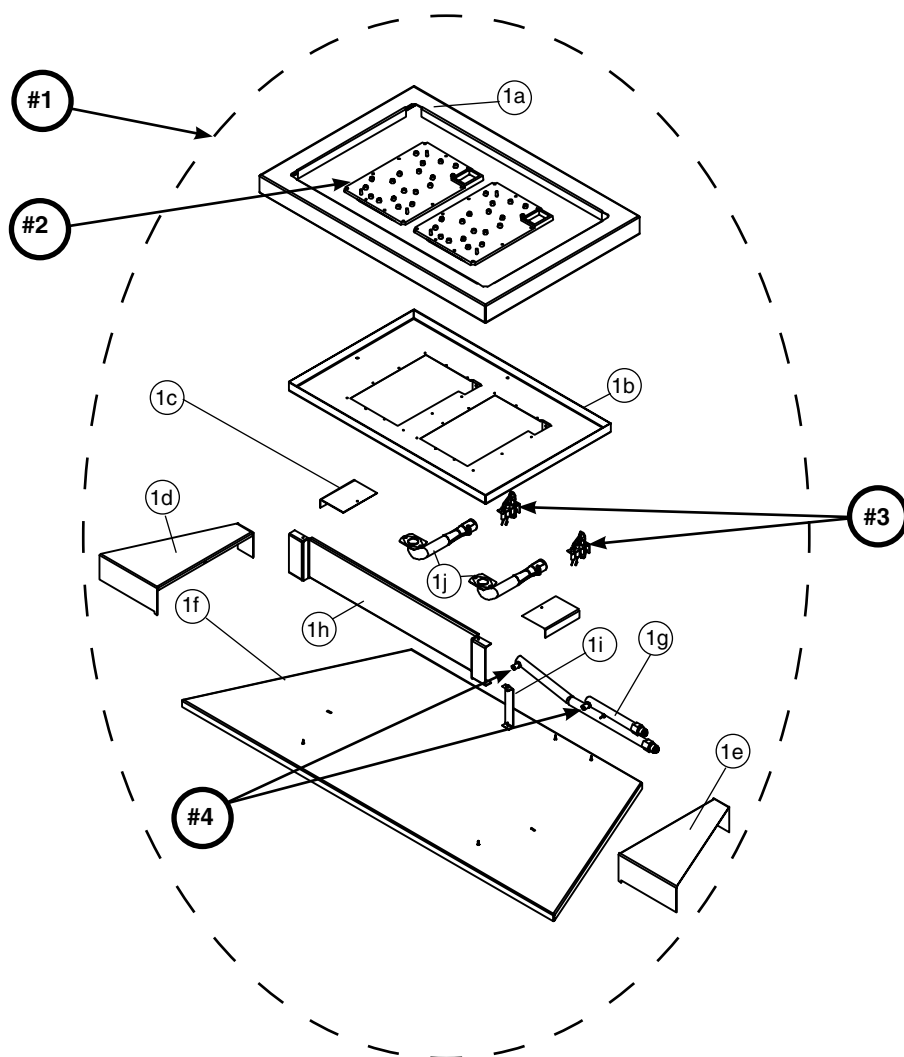

KIT CONTENTS:

- #1.....TC54 TRANQUILITY BURNER KIT
 - 1a TRANQUILITY CURB
 - 1b BURNER TRAY
 - 1c CURB CLAMP
 - 1d LINE COVER, LEFT
 - 1e LINE COVER, RIGHT
 - 1f TRANQUILITY BASE
 - 1g MANIFOLD ASSEMBLY
 - 1h TRAY LEG, FRONT
 - 1i TRAY LEG, REAR
 - 1j BURNER INLET TUBE
 - 2 BURNER
 - 3 PILOT ASSEMBLY, CONVERTIBLE
 - 4 ORIFICE
 - 5 PILOT SUPPLY TUBE...(Not shown)
 - 6 MANIFOLD SUPPLY TUBE
...(Not shown)
 - 7 PEBBLE ASSEMBLY...(Not shown)
 - 8 PROPANE CONVERSION KIT
...(Not shown)
-
- #2.....BURNER
 - #3.....PILOT ASSEMBLY, CONVERTIBLE
 - #4.....ORIFICE, NG (#28)
 - #5 MANIFOLD SUPPLY TUBE...(Not shown)
 - #6.....PEBBLE ASSEMBLY...(Not shown)
 - #7.....PROPANE CONVERSION KIT
...(Not Shown)
 - #8.....7lbs. SAND...(Not shown)



TOWN & COUNTRY
FIREPLACES™

Technical support: 1-877-715-2664
Web site: www.townandcountryfireplaces.net
2975 Allenby Rd., Duncan, BC V9L 6V8